

WEIGHTS AND MEASURES HANDBOOK



PREPARED BY THE EQUIPMENT AND FACILITIES SPECIFICATIONS SUBCOMMITTEE OF THE
NATIONAL OFFICIALS COMMITTEE OF USA TRACK AND FIELD

Author and Editor: George Kleeman

2007-4

- 1 in Jan Changes in Hammer & Javelin Tables in Appendix.
- 2 in Mar Change in Discus in 1.5 kg thickness
- 3 Length of 500 g javelin to conform to WMA Specs.

PRICE \$3.00

This manual is part of the USATF National Officials Monograph Series on how to officiate. Each monograph covers the various techniques for each officiating assignment. These monographs are intended for more in depth understanding of each job. They are intended for both the novice and seasoned official. They cover the real details of the job and how it should be performed. They summarize various techniques to accomplish the job. These monographs can be copied and used for officials training only.

INDEX

	Page
INDEX	i
INTRODUCTION	ii
HOW TO BECOME A CERTIFIED OFFICIAL	ii
PREMEET REQUIREMENTS	1
Facilities	1
Equipment	1
Javelin Board	3
Scale Comparison Table	5
DAY OF THE MEET	8
CHECKING OF EQUIPMENT	8
Recommended Accuracy in Measurements	9
General Procedure for All Implements	9
Shot	11
Discus	12
Hammer	13
Weight	14
Javelin	14
Mini Javelin	17
Use of the TRACKMASTER ^(TM)	19
Use of other Methods	19
Important W & M Differences between Various Rule Books and Divisions	19
APPENDIX INDEX	20

Dedication:

This manual is dedicated to Dr. James Sabatelle of the Metropolitan Association, Carl Strombom and Norm Morrison of the Pacific Association, and Red Meade of the Southern California Association. Jim and Carl were original members of the committee and Norm was one of the original W&M people along with Red Meade on the West Coast. Red was the original manufacturer of the Trackmaster system. Jim was a contributor to the original version of this manual. All were dedicated to helping improve the proficiency of the Weights and Measures Officials in the United States.

INTRODUCTION:

This manual was prepared for Weights and Measures Officials by the Equipment and Facilities Specifications Subcommittee of the Officials Committee of USA Track and Field for the use, education and training of Inspectors of Implements. As such it is copyrighted for the use of USATF members. It is predominately slated to the use of the Trackmaster® and similar measuring equipment although the techniques and procedures are general. Additional copies are available by downloading them directly from <http://www.usatfofficials.com/training/Monograph-WeightsandMeasures2007.pdf>. Comments and recommendations are welcome and can be sent George Kleeman 5104 Alhambra Valley Rd., Martinez, CA 94553-9773 or via E-mail at george_kleeman@comcast.net. It is the first known publication of how to do the job of an Implement Inspector. In addition to this manual there is available a free newsletter for Weights and Measures Officials across the country, published by the subcommittee in January and September. To get on the mailing list write to the same address or e-mail your request.

This manual is intended as a “how to” book for the novice Inspector of Implements as well as a guide to the seasoned veteran. It is an attempt to get more uniformity in the methods used to certify implements and in the measurement techniques being used throughout the United States.

Although the specifications for implements are published in the various rule books of the various governing bodies for track and field, the method of weighing and measuring implements is not specified in any of them. The Inspector of Implements should be able to say that any implement passes because it met every requirement of the rules governing the meet. Only weighting an implement does not approve it for use in competition. It must meet all the measurement standards.

HOW TO BECOME A CERTIFIED OFFICIAL:

At the present time USA Track & Field is the major certifier of officials for track and field. As the national governing body for Athletics in the United States, which includes the sports of Track and Field, Race Walking, Cross Country and Long Distance Running, it is affiliated with the IAAF or the International Association of Athletic Federations which governs the sport worldwide. It is likewise the representative for track and field, race walking and the marathon to the United States Olympic Committee.

There are three levels of officials, Association, National and Master. Each has its own qualification requirements. You begin at the Association level after you have attended an officiating clinic and taken the association level test on the USATF rulebook. Each association sets the requirements for their local area. Some associations require officiating at a certain number of meets as a trainee before you can join. Others only require that you complete a test on the rules. Contact your local association to obtain their requirements. You can get their address from the USATF Website at WWW.USATF.org or by writing the author at the address shown above. At the present time USATF is the only one who are certifying W&M officials for USATF, NCAA, IAAF, WMA (World Masters Athletes) and high schools.

PREMEET REQUIREMENTS:

FACILITIES:

A room at least 10 feet by 10 feet and preferably twice that size with a lock and key and limited access is recommended. You will need good lighting, preferably over the measurement area. If you have a room smaller than this you will have problems checking the javelin, and storing implements until competition time. This is particularly true if it is a two-day or longer meet. It should be located near the field and preferably near the athlete entry gate. Make sure there are adequate signs and announcements about its location. If you do the measurements on the field or outside make sure that the wind doesn't impact your weight measurements. In a meet where you expect a record you may want an additional location near that event where you can set up to be able to quickly recheck an implement during the competition and get it back to the athlete before the next throw. You may also want a writing area. Set up the room so that implements are dropped off at the door and athletes and other people are away from the measurement area. See Appendix.

EQUIPMENT:

The most common measuring and weighing equipment is the Trackmaster^(TM) or the Gill Implement Certification Kit. However, some meets may find the cost prohibitive since it now retails for about \$2200-2600 depending on what you get. Currently there are no specified tools to measure implements. This manual will describe several of those that are available. You can make some of your own if you have access to shop facilities. In the future the Equipment and Facilities Subcommittee of USATF plans to make standards for being able to checking the TRACKMASTER^(TM) and other equipment that is used for implement certification. The alternative TRACKMASTER^(TM) equipment it is made by DAKTRONICS, INC., 331 32nd Avenue, P.O. Box 5128, Brookings, SD 57006, Attn: Jason Moen. The phone number is (888) 325-8766, the fax is (605) 697-4700, their web page is daktronics.com and their e-mail is sales@datronics.com. It comes in six models, Mark V for Collegiate, High School and WAVA, Mark VII for Collegiate and High School, Mark VII for Collegiate, Mark VIII for High School, Mark IX for High School competition without Hammer and Javelin measuring devices and Mark X for scale and carrying case (see page 19 for details). These versions became available in early 1997. The scale is now electronic and has the accuracy of +/- 2 grams and is capable of weighing up to 40 lbs. or 20 kg. The gauges and scale have been reengineered as a result of suggestions from the Equipment and Facilities Subcommittee of USATF. The Gill Implement Certification Kit can also be purchased from Gill Athletics, 201 Courtesy Rd., Urbana, IL 61801-2727, (800) 637-3090, (217) 367-8438, fax (217) 367-8440, and web page www.gillathletics.com. It comes in three types, high school without javelin gauge for about \$1400, high school with javelin gauge for \$1700 and full kit for IAAF, NCAA, USATF, WMA and high school for \$2500. You can order it on line. They also sell implement scales for 10 kg and 20 kg separately. Gill also sells 5 and 10 kg calibration weights.

Measuring equipment must be handled with care and properly stored, maintained and calibrated in order to do the best job. The misuse of equipment is usually the biggest problem and is the result of lack of knowledge or training. Misuse leads to damage which results in inaccuracies even when a competent person is using it.

NOTE: All measurement equipment should be checked at least annually against a known standard. The standard should be traceable to a Bureau of Standards standard. This is true for scales, weights and measurement devices i.e. tapes and calipers. This applies also to those in the TRACKMASTER^(TM) or Gill kit. When you first get it, make sure that all implement measuring devices are measured and marked correctly. Each year check that the gauges have not been damaged, enlarged or otherwise damaged as a result of usage. Alternately for a fee, DAKTRONICS, Inc. will recalibrate your scale if you ship it to them. Any standard must be handled with care and protected so it is not damaged. Standards should not be used for routine checks.

The following is a list of needed equipment for setting up Weights and Measures:

Recommended Personal Equipment:

Steel Measuring Tapes: Normally carry a 3 m tape for implement measuring.

Marking Pens: It is preferable to use paint, particularly on the shot where markings are easily worn off. Mark all implements

the same way with the same color, same location and same mark. If it is more than a one day meet change at least the color and the mark each day. Make it distinctive. Paint sticks are easier to use and are available in your local hardware store, stationary store or hobby shop. Spray paint can also be used but usually takes longer to dry and is not as easy to use. Fluorescent colors stand out more. Broad Line Deco Color Opaque Waterproof Markers or nail polish also works well. You can also use colored dot or square labels on the javelin or discus. They tend to come off too easily on the hammer or the shot. We sometimes use colored tape on the hammer wires particular when it is wet since it seems to stay on better than paint.

Adhesive Tape: For putting names on equipment, laying out javelin measuring tape.

Masking Tape: For putting up signs and schedules.

Implement Labels and Form Sheets: Use computer labels to indicate event and name of the implement owner. This helps in tracking implements through the weigh-in process. When used with the implement forms in the Appendix you have a control system for all implements.

Men Decathlon Shot	Women Open Shot
Name _____	Name _____

If you use the form with carbon paper then the event judge knows exactly how many implements were checked in and whose implements did not pass. The labels are particularly useful when you have multiple events or flights in the same event such as they occur in Masters and Youth Meets. Samples are attached in the appendix. An alternative is to use the DYMO® electronic tape type device to label each implement. The hardest to keep the label on is the shot, particularly if the landing area is rock or gravel.

Stencil: The more distinctive the better. You can buy a plastic geometric or engineering symbol guide at your local stationery store. Alternately you can make your own stencils out of plastic, metal or wood.

Square: Used to test the overall hammer length.

Paperwork: Have a current meet schedule so you know which implements to do first and when to take implements out to the field.

Weights and Measures Signs: Paper signs to indicate location of Weights and Measures in a plastic cover.

Weights and Measures Spec Tables: Complete tables of specifications for all implements from this manual in plastic covers for ready reference. Tables are in the appendix.

Weights and Measures Implement and Impoundment Forms: (see example in Appendix)

Poster/Sign Marking Pens: Some Marks Lots should be available in your kit for emergencies but these aren't the best marking devices unless you're making signs.

Level: Used to level scale location.

Calculator: For use in calculating percentages for javelin measurements.

Caliper: Used to measure the hammer wire diameter and the various points on the javelin. You might want to consider an electronic one. If you do, keep an extra battery in the box. If it has at least 3 inch jaws it can be used to measure discuses, weights and shots as well as the javelin profile.

Handbook: Keep a copy of this handbook in a folder. Note included in back are the implement specification tables for all implements in case the individual sheets getting misplaced.

Straight Edge: at least 50 centimeters long as a fast check of the javelin taper or to measure the taper when used with feeler gauges.

Javelin Measuring Gauge: You can make your own out of wood or even tape on the edge of the table. The following example was made in three pieces so it could be easily transported. It is color coded so that all three javelin weights can be easily measured. In fact, it can also be expanded to do the 500 and 700g implements. The dimensions are:

- Overall Length: 9 ft. / 2.73 m
- Overall Width: 3" / 9 cm for 3 or 6" 18 cm for all 5
- Each Piece: 3 ft. / 0.91 m

It is made out of hardwood with pieces of shelf hanger pieces as sides so the javelin doesn't roll off. All marks were engraved into the wood before it was painted for accuracy. The three boards are held together by hinges and pins to assure that the length is always the same. Alternatively, the javelin board could be laid out on a paper or cloth template that could be rolled up and then tapped to a table or the floor. Then you would only need to have a hinge or other sharp edge that you could place at the balance point. Although this one is only set up for three javelins, you can lay one out of all 5 weights. If you do I suggest you use a 6-inch wide hardwood board.

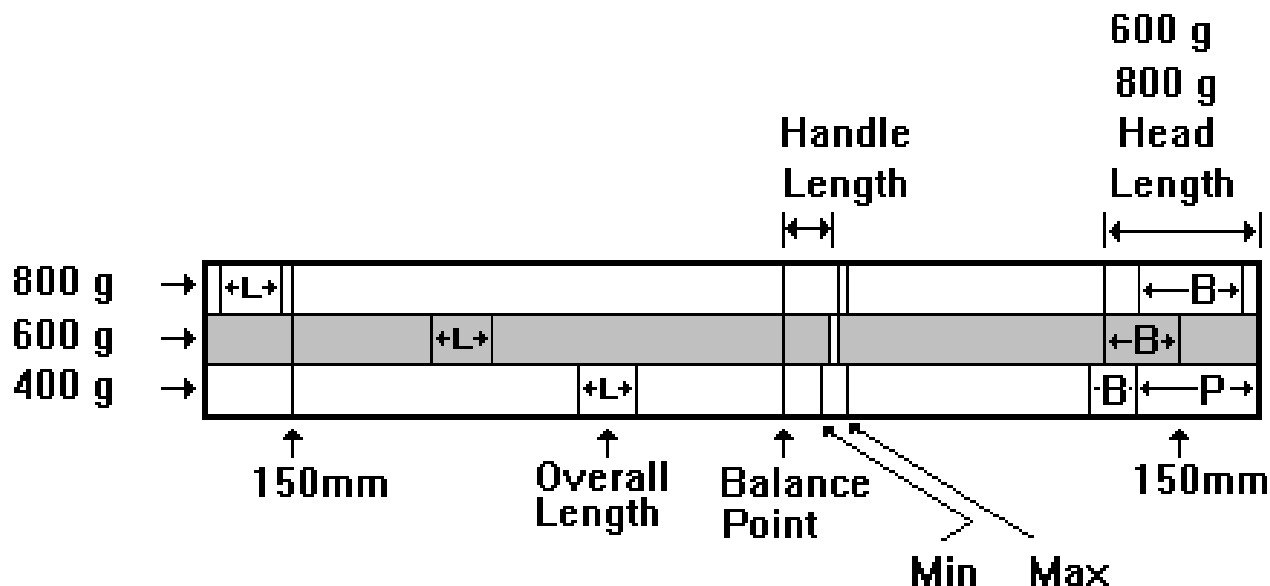

L=Overall Length
 B=Balance Point
 P=Point Length

JAVELIN BOARD

Not to Scale

Other Miscellaneous Equipment:

- Wet and Dry Towels for Cleaning Implements
- Wheelbarrow, cart, wagon or Grocery Cart for transporting implements
- Boxes for segregating impounded implements, yet to be weighed and approved implements
- Signs for Location of Weights and Measures

Notebook: To do any needed calculations and to record calibration procedure. Also record the following information on any implement that is impounded. Owner/Athlete, School, type, brand, failing parameter, condition of implement, i.e. is failure due to wear or damage or is it a new implement. See Appendix for a sample Weights and Measures Inspector of Implements form.

Rulebooks: Always have a current rulebook for the type and level of meet you are officiating. The specifications required are slightly different in some cases, particularly in the high school rulebook. They can be purchased as follows:

(1) National Federation of State High School Associations

P.O. Box 690
Indianapolis, IN 46206
317-972-6900
www.nfhs.org

Published in 3 volumes at \$6.95 each, Rules, Officials and Case Book. Rulebook and case book are annual and the Officials book is biannual plus \$7.95 shipping charges. You can order by fax or e-mail with a credit card.

(2) National Collegiate Athletic Association

P.O. Box 6222
Indianapolis, Indiana 46206-6222
317-638-9550
www.ncaa.org

Cost of \$7.75 annually plus a shipping charge of \$5.95. You can order by e-mail. Its case book is on line.

(3) USA Track and Field

USATF Book Order Department
P.O. Box 120
Indianapolis, In 46206
317-638-9550
www.usatf.org

Cost of \$13.00 annually. You can order by e-mail.
Members get a 10% discount.

(4) International Amateur Athletic Federation

17, rue Princesse Florestine
BP 359 - MC 98007
Monaco Cedex
(377) 93 10 88 88
Fax (337) 93 15 95 15
www.iaaf.org

This is also available from USATF. Cost of \$10 biannually from IAAF. You can order by e-mail.

Equipment from the Meet Site:

Table: At least one which 6 feet long and preferably three or four tables. One would be use for your scale and measuring instruments, one for doing the measurements and one for implement check in. Make sure you have plenty of room particularly if you are doing the javelin. A solid table is preferable to a folding table. A couple of chairs are always useful.

Scale: Preferably a double pan balance or electronic scale capable of measuring to at least 1 part in 3000. The desired tolerance is 1 part in 10,000 (10 mg per 1000 g or per kg) to meet the National Bureau of Standards Class Field Standards for weights (NBS Class F) over 700 grams which covers all but two javelin weights. At 600 g the tolerance is 70 mg while at 400 g, it is 45 mg. (see tables below for full spectrum of weights of interest for field events implements. (Note in this discussion and throughout this manual, I am going to use tolerance and accuracy interchangeably although scientifically they do have slightly different meanings.) However, that tolerance is quite expensive, usually costing in excess of \$1000 for an electronic scale with

this accuracy. The recommended tolerance is about 3 parts in 10,000 although 1/2000 that is typical of the older TRACKMASTERTM units which has been the past standard. The Equipment and Facilities Specifications Subcommittee recommends use of a scale with at least a tolerance of 1/1000 or 1 g in 1 Kg. But the use of any scale is better than the use of none. The following table may be of use as you look for a scale. There is no intent to endorse any of the scales shown, only to show the relative cost in 1997 for the various tolerances. Note the wider the range desired, the lower the relative tolerance. A scale rated to cover more than about 20 lbs. will generally have half the tolerance of the comparable scale for the range less than 20 lbs.

Columns 1 and 2 contain the manufacturer's name and model number. The next column is the maximum capacity of the scale. The fourth column indicates the smallest increment that can be read. Note the differences when there are two ranges. The comments column contains any special considerations listed by the manufacturer in the literature. The next column is the percentage accuracy expected. Note rows 1 through 3 are the National Bureau of Standards requirements at those weights for comparison purposes. This accuracy is shown as error in part per parts measured in the last column labeled accuracy, i.e. 1 part in 10,000 means that the error will be only 1g in 10 kg. The next column contains where that scale may have been used in 1996 when the data was collected. The eighth column contains the 1996 costs. The next to last column is quantification of whether the particular scale is better than, equal to, or less than the NBS Standard is. The final column is the accuracy claimed for the scale.

SCALE COMPARISON SUMMARY

MFG	Model	Capacity	Increment	Comments	%	Where Used	Cost	NBS F	Accuracy
NBS Class F		50 lb.			0.01	Standard		Standard	1/10000
NBS Class F		20 lb.			0.01	Standard		Standard	1/10000
NBS Class F		2 lb.			0.01	Standard		Standard	1/10000
Toledo	SM 15000	33 lb.	0.1g	Build in calib.	0.00066			Better	1/150000
Toledo	BP3260	70 lb./14 lb.	1g/0.1g	ISO 9000	0.003/0.0016	Olympics	\$4500	Better	1/64000 & 1/32100
Toledo	BP1630	7 lb./35 lb.	0.1g/1g		0.006/0.003			Better	1/32000 & 1/16100
Ishida	QB-12KE	26 lb.	1g		0.008			Better	1/12000
Pennsylvania	7000	25 lb.	0.005 lb.(2g)		0.02	Houston	\$650	_	1/5000
Pennsylvania		50 lb.	0.01 lb.(4.5g)		0.02			1/2f	1/5000
Pennsylvania		100 lb.	0.02 lb.(9g)		0.02			1/2f	1/5000
Doran	8020	20 lb.	1g		0.01	LA	\$1100	Meets	1/10000
New Trackmaster	Toledo	40 lb.	1g					Standard	1/10000
Doran	8030	30 lb.	5		0.037			_	1/2700
Doran	8060	60 lb.	0.01 kg(10g)		0.037			_	1/2700
Old Trackmaster		16 lb.	0.05lb			Older		1/5	1/2000
CCI	TLEC-10	10 lb.	5g		0.1	Ohio	\$230	1/10	1/1000
CCI	TLEC-20	20 lb.	10g		0.1		\$255	1/10	1/1000
CCI	TLEC-50	50 lb.	20g		0.1		\$285	1/10	1/1000
Pelouze	4010	125 lb.	0.1kg(100g)			Penn	\$150	1/17	1/600
Bathroom		300 lb.	1 lb.		0.1677				1/40
Minimum									1/1000
Suggested					0.03			1/3 or better	3/10000

Class F Tolerances for Field Standard Weights

Nat. Bureau of Standards Handbook 105-1

lb.	kg	g	1/10000 Value (down to 1.5 lb.)	NBS Class F Tolerance	Implement Weights in that range
50	22.679	22679.3	2.268 g	2.3	56lb
30	13.608	13607.6	1.361 g	1.4	35 lb.
20	9.072	9071.7	0.907 g	0.91	20 lb.
10	4.536	4535.9	0.454 g	0.45	16lb/12lb/4kg
5	2.268	2267.9	0.227 g	0.227	2kg/1.6kg
2	0.907	907.2	0.091 g	0.091	800g/600g
1	0.454	453.6	0.045 g	0.070	400g

Tolerances for Implements

Based on full use of Class F Standards

Implement lb.	Weight Kg	Weight G	Tolerance 1/10000	NSB F Table	Tolerance G (1/10000)	Tolerance Mg (1/10000)	Recommended Tolerance g (1/3000)	Recommended Tolerance mg (1/3000)	Implement Name
56	25.40	25400.8	2.540	2.3	2.54		7.62		56# Weight
35	15.88	15875.5	1.588	1.4	1.59		4.76		35# Weight
25	11.34	11339.6	1.134	0.91	1.13		3.40		25# Weight
20	9.07	9071.7	0.907	0.91	0.91		2.72		20# Weight
16	7.26	7257.4	0.726	0.45	0.73		2.18		16# Shot/Ham./Weight
	6.00	6000.0	0.600	0.45	0.60		1.80		6k Shot/Ham./Weight
12	5.44	5443.0	0.544	0.136	0.54		1.63		12# Shot/Ham./Weight
	5.00	5000.0	0.500	0.45	0.50		1.50		5k Shot/Hammer
	4.00	4000.0	0.400	0.227	0.40		1.20		4k Shot/Hammer
	3.00	3000.0	0.300	0.227	0.30		0.90		3k Shot/Hammer
6	2.72	2721.5	0.272	0.227	0.27		0.82		6# Shot
	2.00	2000.0	0.200	0.136	0.20	200	0.60	600	2k Discus
	1.60	1600.0	0.160	0.136	0.16	160	0.48	480	1.6k Discus
	1.50	1500.0	0.150	0.136	0.15	150	0.45	450	1.5k Discus
	1.00	1000.0	0.100	0.091	0.10	100	0.30	300	1k Discus
	800.0	800.0	0.080	0.070	0.080	80	0.24	240	800g Javelin
	600.0	600.0	0.060	0.070	0.070	70	0.21	210	600g Javelin
	400.0	400.0	0.040	0.045	0.045	45	0.14	135	400g Javelin

When using a double pan balance the weights go on the left and implements on the right. This can be tested by moving the ounce slide to the 1 ounce and see which way the balance moves, i.e. it take one ounce of weight or pressure on the side which should have the implements to rebalance the scale to zero. Note some of the scales have a plus and minus designation to indicate over weight or underweight.

Remember every measurement has some level of error or uncertainty in it. For a scale that uncertainty is called tolerance. Every scale but even an electronic scale has a degree of uncertainty. However, because there is a digital read out people tend to believe all the significant places shown. Within the tolerance/accuracy of that scale you cannot tell if the scale is weighting lighter or heavier than the indicated weight by plus or minus that tolerance. Or put another way you cannot tell the difference between the following two implements: one that weight exactly at the measured weight minus the tolerance and one that weighs the measured weight plus the tolerance. Thus a scale that can measure to plus or minus 1 gram in a kilogram cannot tell the difference between a 1 kg discus weighing 999 g and 1001g or 0.999 kg and 1.001 kg. Both could read 1.000 kg on the scale. Similarly if a discus showed 0.999 kg it could weight 1.000 kg or 0.998 kg. Thus you would have to accept as legal a discus that weighed 0.999 kg on this scale but not one that weighed 0.998 kg. This is statistical reality. Obviously if you have a more accurate scale with a lower tolerance then you might be able to distinguish between the disci. Remember that there is a tolerance for any scale but particularly the electronic scale. Because there is a read out people tend to believe

all the numbers.

Weights: Unless you are using an electronic scale, you will need the following weights depending on the competition. This can be accomplished with 1, 2, 5, 10, 20 lb., 1, two 2, 5 kg and 50, 100, 300, 400, 600 and 800 g weights. This allows you to weigh all implements up to the 35 lb. weight.

	Men's Open	Women's Open
Shot and Hammer	16 lb.	4 kg
Javelin:	800 g	600 g
Discus:	2 kg	1 kg
Weight	56, 35 lb.	20 lb.
	Junior Men	Junior Women
Shot and Hammer:	6kg	4 kg
Javelin:	800 g	600 g
Discus:	1.75 kg	1 kg
	Collegiate Men	Collegiate Women
Shot and Hammer:	16 lb.	4 kg
Javelin:	800 kg	600 kg
Discus:	2 kg	1 kg
Weight:	35 lb.	20 lb.
	Men's Masters	Women's Masters
Hammer:	3, 4, 5, 6 kg, 16 lb.	3, 4 kg
Shot:	3, 4, 5, 6 kg, 16 lb.	3, 4 kg
Javelin:	400, 500, 600, 700, 800 g	400, 500, 600 gm
Discus:	1, 1.5, 2 kg	0.75, 1 kg
Weight/Superweight:	12, 16, 20, 25, 35 lb.	12, 16, 20 lb.
Ultraweight	35,44,56,98,200,300 lb.	35,44,56,98,200 lb.
	High School Boys	High School Girls
Shot:	12 lb.	4 kg
Javelin:	800 g	600 g
Discus:	1.6 kg	1 kg
	Youth Boys	Youth Girls
Shot:	6, 12 lb., 4 kg	6 lb., 4 kg
Javelin:	800 g	600 g
Discus:	1, 1.6 kg	1 kg
	IAAF Boys	IAAF Girls
Shot and Hammer:	5kg	4 kg
Javelin:	700 g	600 g
Discus:	1.5 kg	1 kg

Athletics for the Disabled:

Cerebral Palsy	Javelin	Discus	Shot
	600 g	1, 1.5 kg	4, 6 lb., 3, 4, 5 kg
	800 g		

Wheelchair	600 g 800 g	1, 1.5kg	2, 3, 4, 5 kg 4, 6, 8 lb.
Blind	400, 600, 800 g	1, 1.5, 2.0 kg	3, 4, 5, 7.26 kg
Ambulatory	600, 800 g	1, 1.5 kg	4, 5, 6.25 kg
Special Olympics			3, 4, 6 lb., 4 kg
Hearing Impaired	800 g	2.0 kg	7.26 kg

Weights should be handled with care so as not to damage them so they either gain weight, less likely or loose weight by being dropped.

Ultraweights:

Age Group	Weight	Super-Weight	35#	44#	56#	98#	200#	300#
MEN								
Open-49	35	56				x	x	x
50-59	25	56				x	x	x
60-69	20	56				x	x	x
70-79	16	35			x	x	x	
80+	12	25	x		x	x		
WOMEN								
Open-49	20	35			x	x	x	
50-59	16	25	x		x	x		
60-69	12	25	x	x	x			
70+	12	20	x	x	x			

See Rules 195.8 & 9 for further specifications and 202 for updates for this table.

The accepted conversions (although not exact) are:

Lb.	Kg	Lb.	Kg.
12	5.443	25	11.340
16	7.260	35	15.880
20	9.080	56	25.400

Note: There are 16 oz in a lb., 453.5924 g per lb., 28.349527 g per oz, and 2.20462 lb. per kg. Only the 6 and 12 lb. shot since they are a youth and a high school implement are still weighted in pounds. The other weights have been accepted internationally and have taken on the metric weight equivalent shown. **NOTE: For NCAA meets accept weight implements weighting 20 lbs and 35 lbs via discussions with Bob Podkaminer and NCAA Rules Committee in February, 2006.**

DAY OF THE MEET:

1. Arrive early at the site to make sure equipment being supplied by the meet is present and in good working order. Normally this should be at least two hours before the first throwing event. If possible, do it before the day of the meet.

2. Let the appropriate Head Judges of Events and the Field Referee know what mark, what color paint and where you plan to mark each implement. If you know you have the possibility of a national or world record, let both know where you and your equipment will be. You may want to try to have an area on the field near the event where an implement could be rechecked during the competition.

3. While returning to the Weights and Measures room make sure there are adequate signs to direct athletes to your location

from where they will normally enter the track. Post times for weigh-ins. Make sure you have a copy of the event schedule and post it nearby. It will avoid answering the same question about when events are scheduled.

4. Set up the Weigh-In room. Set aside an area for receiving and marking implements with the athlete's name or school. This should be near the door to keep athletes away from the measurement area. Set aside an area for storing the implements that are ready for competition. Set aside an area for impounded implements that do not meet specifications and set aside an area for measuring implements. It is important that each of these areas is segregated to avoid problems. See previous drawing on page 3.

5. Set up your measuring equipment. Pay particular attention to having your scale level. Place the scale so it won't have to be moved to do the various implements. Cross check your scale versus a second scale or standard. You may find you need to have two calibration weights one at the low end and one at the high end, i.e. 400 or 600 g and 8 kg. Layout your javelin measuring tape. Try to have separate areas for each implement or implement measurement. If there is more than one person working, make sure there is enough room to move around, particularly with the javelin. It becomes more difficult if the ceiling is not at least 9 feet to allow the javelin to be turned vertically.

6. Set up an implement check-in sheet. Have room to record the name of the individual, school and manufacturer for all implements measured and/or impounded. The Equipment and Facilities Specification Sub-committee would like the information on impounded new implements so that we can work with the manufacturers to get better equipment and to gather statistics on what are the common reasons for implement impoundment. This will help us all so we can better order the suggested order of the measurements to be made on the various implements. Send the information to the chair, George Kleeman, 5104 Alhambra Valley Rd., Martinez, CA 94553-9773 or fax to 925-229-2940 or e-mail to george_kleeman@comcast.net.

7. You should be prepared to make your first measurement at least an hour to an hour and a half before the first throwing event. If the implements are to be brought to the field by you, then you take them out to the venue so that they will be available at least 10 minutes before the start of warm-up for the event is scheduled. Typically this is about 30 minutes. Make sure to turn them over to an event official and not just leave them on the field.

CHECKING OF EQUIPMENT:

The following sections are ordered such that the normal reasons for an implement to fail are checked first so that you minimize time spent on equipment that eventually will not pass. The order is the consensus of some of the most experienced implement qualifiers in the country. If you want to do in a different order fine but get an order and stick to it, so you don't forget a measurement.

RECOMMENDED ACCURACY IN MEASUREMENTS:

1. As discussed under the scales section on equipment, the Bureau of Standards recommends an accuracy of 0.01% or 1/10,000. This is equivalent to 0.1g per kg or 10 mm (1 cm) in 100 meters. However, because of cost and because many older scales continue to be used the E&FS committee recommends a minimum of 0.03% for weight.

2. Based on the accuracy for measuring record heights by steel tape and the impact of temperature, plus the recommended procedures for certifying electronic measurements, the accuracy varies from 0.04% to 0.17% for sector lines in the long throws. The EF&S Committee recommends a minimum standard of 0.1% which translates into 0.1 mm for a 100 mm shot. This means gauges used for implement measurement should be accurate to 1 part in 1000. If they are properly manufactured you should be able to get them to about +/- 0.005 inch or 0.127 mm or 7/10000 versus our recommendation of 10/10000. However, the proper care and handling is mandatory in order to maintain its accuracy. Remember any standard has some error in it. Note a variation of 36 degrees F (20 degrees C) of a linear measuring device can change the reading by some about 0.24 mm per m. This may be additive to the tolerance limit. Thus if you have an implement just missing the spec and there is a large temperature difference between the measuring device and the implement or the measuring device and the temperature at which it was calibrated, pass the implement. This illustrates why it is good practice not to have the implement or the measuring equipment in the sun

Basis for Accuracy Measurements

Type of Measurement	Expected Accuracy	Measurement	%	Parts/ 1000
Pole Vault Electronic	+/- 2 mm	5 m	0.04	0.4
High Jump Electronic	+/- 2 mm	2 m	0.01	1
Discus/Hammer Sector	+/-164 mm	100 m	0.164	1.64
Javelin Sector	+/- 169 mm	100 m	0.169	1.69
Temperature Correction at 10 deg. C difference	+/- 12 mm	100 m	0.012	12
Weight , NBS F	+/- 0.07 g	700 g	0.01	0.1

GENERAL PROCEDURE FOR ALL IMPLEMENTS:

1. Have an implement check-in sheet on which each athlete signs in and indicates how many and what type of implements he or she is leaving. Have tape or labels and pens available so they can put their name and their school name, if appropriate, on the implement.
2. Try to have a box or some other appropriate holding device for the implements being left for weigh-in so they don't get mixed in with previously certified implements.
3. Check each implement for internal movement (if that is a requirement like for the javelin) or loose connections when you first pick it up.
4. Check the general appearance. Is this a homemade implement or a modified implement? Are all the original pieces there? Does it have the expected shape? There should be no significant nicks, gouges, and logos, decals or movable implement weights or parts that would give an advantage for a better grip or better aerodynamics.
5. Does the implement have previous weigh-in markings?
6. Does the implement have a name on it, in case you have to impound it, so it can be identified for picked up later?
7. Is the implement clean or does it need to be cleaned of dirt, tape or other removable debris which might affect weight or center of gravity before you certify it? Note a single piece of tape or label should not make enough difference in weight or balance that it need to be removed. Your equipment is not accurate enough to detect that small of a change.
8. Weighing is first because it is the most common reason for implement failure. Constant use and damage tend to reduce the weight of an otherwise legal implement. When checking the weight of the implement, do it carefully. There are three common types of scales used. Any scale which can or has been certified by your local or state authority is acceptable. The three are electronic, balance and lever or beam. Be aware that there have been two different types of the beam scales used in the Trackmaster™ kits over the years. The older versions of the TRACKMASTER™ made by Red Meade or by Jack Balko used a beam scale. Red Meade made those units with serial numbers below 180. Make sure you know how you have calibrated it. Normally put the calibration weights on and then set the balance point. To pass an implement must be at or above the balance point. The new version by Daktronics uses an electronic scale. Since we can't be exact, err on being fair to the athlete. If an implement fails on one scale but passes on another, let it go unless you know there is significant difference in calibration or tolerance of the two scales. If it is that close to weight, it really will have any impact on the competition or a record. (See previous section on scales for discussion of accuracy and tolerance.)

NOTE: When using any scale, treat it carefully. When removing implements or weights from the scale, make sure to do it gently so that you do not damage the knife edges or bearings. This is particularly true for a single pan balance such as that used in the TRACKMASTER™. Hold the bar when removing weights or implements so the bar doesn't damage the knife

edges or bearings. With care, your scale will last a long time. Without this care you can damage it very quickly. Remember, scales and weights need to be calibrated periodically. With normal use that should be at least bi-annually if not annually. When moving scales make sure to protect the knife edges or bearings by immobilizing the scale. You can use foam rubber under the arm and/or on top of it for protection. You should calibrate the scale before use each day or each time you move it. For the double pan try weight two identical weights and then switching them to make sure you are balanced and level enough. Try to keep the scale out of the wind since the wind can impact even an electronic scale.

Before putting any weight on the scale, test the movement of the pan(s) to make sure it moves easily and isn't bound by anything. When putting an implement on the pan make sure it is well balanced. For hammers, shots and weights, you can use a washer on each pan (so balanced) to stop the implement from rolling. On an electronic scale with one pan you can tare the weight out. For the hammer put the ball in the handle loop. Be careful because if you have a new wire, it may spring out. Make sure the wire isn't hitting anything while you are trying to weight the hammer. For the javelin, the center of gravity is near the front of the handle so tend to place the javelin so that the front of the handle is near the center of the pan. In general you should place the weights and the implements as near to the center of the pan as possible (see also discussion of tolerance/accuracy under the equipment section on scales).

9. Continue on with the other implement specific tests.

10. If the implement passes all the tests then mark it. Mark it at a place where the paint or marking is less likely to come off, like at the weight mark, the hex screw, near the swivel on the hammer ball or just in front of or behind the grip. Some inspectors mark javelins near the tip, but I find it can come off more easily there. Some use symbols, some use lines, some use initials and even dates. Make sure the mark is dry and then place it with the other approved implements for the day. This is the recommended procedure. But if you are short of help, you may need to return it to the athlete to transport it to the competition site.

11. If you are impounding an implement, let the athlete know the reason why and when he or she can pick up the implement after their event. Record the reasons for impounding any implement in your notebook, on the check-in sheet and place a piece of tape or label on the implement. This will save you time if there is a protest or the coach or referee becomes involved. This way you can quickly find the implement in question and show them quickly why you made your disqualification.

12. If possible, take the implements out to the competition area about 35 minutes before the competition is scheduled or at least ten minutes before the expected start of warm-ups or have an event official pick them up from you. Always turn over the marked implements to an event official it at all possible to insure the chain of custody and make sure no implements are lost.

The following sections detail how to certify each of the implements. Because there are subtle differences between the wording in each rulebook, it is always a good idea to review the rulebook the night before the meet. This is particularly true if it is for a meet that is using a different set of rules than you have recently been using. Always use the rulebook as the ultimate authority, unless you know there has been an intervening change. The EF&S committee tries to keep you apprised of these changes as they occur during the year. If you have e-mail, send your address to george_kleeman@comcast.net so that this can be done in a more timely fashion. These sections try to point out the similarities and the differences between the various rulebooks.

When demonstrating to athletes or coaches how much their implement is light you can use the following table for coins as an indication, thanks to Shirley Crowe and Emmitt Griggs:

Coin	Weight, kg
Dime	0.0020
Penny	0.0025
Nickel	0.0050
Quarter	0.0055

SHOT:

1. Note: internal movement by sound or feel is no longer a reason to impound a shot. . Make sure that the weight stamp or the

plug cannot be used as a finger hold. Some screw the plug in beyond being even with the surface. This was a new emphasis point in the 1998 HS rules. If the shot has a removable plug for weight adjustment, you can either 1) seal it with bath tub sealer or Elmer's glue if it appears loose so it can't be tampered with or 2) make a mark across one side of the plug to indicate the location of the plug when it was checked. Elmer's glue can be bought in colors so it can't be easily replaced, but the use of glue has the disadvantage that it takes longer to dry. Unless someone has recently opened it, most plugs are hard to remove, so a mark across it is adequate.

2. The shot should be smooth. In fact the IAAF and USATF require a maximum roughness of N7. Check for finger holds, cracks or dents. Look for out of roundness by sight or feel. It should be essentially spherical, i.e. no significant flatness spots that might help gripping. Assume it is spherical if passes the diameter in step 4 in a minimum of at least three out of four different planes including the plane in which the flat spot occurs. If there is a significant flat spot, i.e. a several millimeter gap, then fail it. Some practice shots and over weight shots turn up at meets. These shots are usually cast iron and have such a large imprint of the weight that it can act as a finger hold. If in your opinion use of this implement would give a thrower an advantage or it is dangerous then impound the implement. The shot may be rolled to check eccentricity thus indicating that the center of gravity is off of center. However, there is no specification for this and thus should not be used to disqualify an implement.

3. Weigh the shot. Make sure the shot is clean of any foreign substance that might significantly affect the weight. If just at weight, recheck it to make sure it is clean and that removal of any debris ownership doesn't cause it to drop below the minimum. Normally the tolerance of your scale won't be sufficient to measure such small differences. Note if you are using a double pan scale place an equal size washer on each pan to keep the shot from rolling off the pan, and place the weight on one pan and the shot on the washer on the other one. The men's shot weighs 7.260 kg and the women's 4.000 kg. For other weights see the previous chart or the tables in the Appendix. If you are using the older TRACKMASTER^(TM) use weights #1, 4 and 8 for the men's shot, weight 7 for women's shot, weights 5 and 6 for the Junior men's and weight 6 for the Junior women's shot. Remember that there is a tolerance for any scale but particularly the electronic scale. Because there is a read out people tend to believe all the numbers. It means that within the tolerance (accuracy for measuring with that scale) you cannot tell if the scale is weighting lighter or heavier than the indicated weight by plus or minus that tolerance (see section on scales under equipment for further details).

4. Check the minimum and maximum diameter in at least three locations with the appropriate diameter gauge. For Men the respective diameters are 110 mm and 130 mm while for women they are 95 mm and 110 mm. For other dimensions see the tables in the appendix. If all three diameters pass, pass the implement. If one or more fail, check at least two more locations. If you can't get at least three acceptable measurements impound the implement. For indoor competitions, each of the rulebooks is slightly different. The acceptable maximum diameters are slightly larger for synthetically covered implements in USATF and IAAF meets, 145 and 130 mm respectively. As dictated by the facilities and the Games committee, outdoor metal shots or one made with a synthetic (rubber or plastic) cover or filled with shot may be used provided they meet weight. To cover the Masters implements the USATF generalized the diameter rule to the diameter for a synthetic covered indoor shots can be a maximum of 15 mm larger than the corresponding outdoor men's shot and 20 mm larger for the corresponding outdoor women's shot. In 2001 USATF and IAAF specified that only indoor or outdoor implements can be used in the same competition, not both.

NOTE: 1) Some of the new stainless steel shots have not been making the minimum diameter.

5. If it meets all of the requirements, mark it and put it with the other approved implements for that event. If not then see step 11 above in the general procedures section.

DISCUS:

1. Check the rim and nearby surfaces for dents, cracks, or roughness that would aid the grip. All discuses must have metal rims with the exception of high school where they allow the use of the rubber disk. Check implement for any loose parts. If there are any significant hand holds impound it. Normal wear or minimum damage is acceptable. Some athletes have been known to dip discuses with wooden centers in water in order to make weight if they are otherwise light. On a hot sunny day a wet implement will dry quickly and therefore, be light during the competition. Impound any wet discus. Be sure the profile of both sides is the same. One way to check the contour is to lay a straight edge on each side. It should hit both the center flat

spot and the rim without having to be rocked to be legal. That is there should not be any concave or convex style to the discus sides. If there are dents, that is OK as long as they aren't along the edge or too big. A discus is held at the edge so indents further in should not give a thrower an advantage. A broken or cracked metal ring is reason enough to impound a discus. Safety should be a major concern. But since the discus is held at the rim, small dents and cracks on the side of the discus should be allowed since they don't help holding the discus, unless they impact the integrity of the discus.

NOTE: 1) A 1993 USATF and IAAF rule changes limited the degree of roughness allowable on the edge of the discus. Manufactured grooves in the metal rim or elsewhere are not allowed.

2) The PACER Gold Plus was declared illegal for USATF and IAAF competition because it was weighted more on side that the other. Although the NCAA did not declare it illegal, their rules read the same as the USATF and IAAF on the conformity of the discus which in my opinion makes it illegal. The high school rule is less clear and therefore is probably legal since there is no mention that both sides need to be the same. This discus was weighted on one side more than the other as part of the manufacturing process.

2. Weigh the discus. The Men's discus is 2 kg while the women's is 1 kg. The high school discus is 1.6 kg. See appendix for other weights. Using the older TRACKMASTER™ the weights are: Men's 1 and 4, Women's 2 and Junior Men's 3. The Junior Men's discus is 1.75 kg. The Master's have a 1.5 kg discus.

3. Gauge for diameter (219-221 mm for men and 180-182 mm for women see Rule 189 or the appendix for others), center diameter (50-57 mm), and center (44-46 mm for men and 37-39 mm for women) and the minimum edge (12 mm) thickness. Check at least three points for each dimension to insure adequate roundness and thickness. Note the minimum thickness of the edge should be measured at a point 6 mm in from the edge. Check the center discus to be sure that it is flush with the mating surface. For dimensions of other discuses see the Appendix. Note that the flat surfaces must meet the dimension, not necessarily the metal plates. Note a discus does not have to have metal plates and some have metal plates smaller than the whole flat surface (Early Denfi discuses ~ 1995). Both are OK. In measuring the edge thickness of the discus be sure that the measuring tool is perpendicular to the sides. The early edge thickness measuring devices included in the 1997 and early 1998 Trackmaster™ kits from Daktronics were too thin so that if not held properly might indicate a correct thickness when it really was too thin. This gauge should be at least 1/4" thick to minimize this problem since at this thickness it is hard to use the gauge and not be perpendicular to the sides. This gauge must be very accurate since you are trying to measure the edge thickness. It is suppose to be at least 6 mm thick at 12 mm. The easiest way and most accurate way is with a gauge. The edge of a discus is supposed to be a semicircle, which is a minimum of 12 mm in diameter and a maximum of 13 mm. Thus one gauge should be a 12 mm diameter semicircle and the other 13 mm. If it fits in the 12 mm gauge and doesn't rattle, it meets the minimum thickness. If it rattles it is too thin and fails. If it doesn't fit into the 13mm gauge then it is too thick. Gauges are available from Springco but make sure to verify the measurement when you get them with a good caliper.

4. Check the taper of the sides by laying a straight edge on the side from the center plates to the rim. It should be in contact with the side all the way to the metal edge.

5. If the implement passes, then mark it and set it with the other approved implements. Try to mark on the top of the discus rather than the bottom. You can usually tell since the label is on the top or the scratches are all on the bottom. If it does not pass, note the same information as listed in section 10 of the general procedure section as to the reason for failure.

6. If the discus rattles or the plate is loose or the discus is too thick, try taking it apart with an Allen wrench and see if cleaning out the edges or putting some tissue in the center won't clear up the problem. Often the plates get tightened too much and the edges come up so that the discus is too thick. If you take the flat plates off and hit them with a hammer the usually straighten out and fit back in the groove. If you dismantle a discus make sure you know which side and which plate go on which side. Particularly discuses that have been used may be out of round and thus may only fit back together one way. Mark the plates, the sides as well as the rim before you take the implement apart.

HAMMER:

1. Check the hammer head for internal movement, dents, cracks and a plug for adjusting the weight. If there is a plug then seal or mark it as described in the shot section. Make sure the head is reasonably spherical and made of iron or other metal

not softer than brass. (See discussion for the shot and the diameter below.) Check to see that the swivel is free to move.

2. Check both the minimum and maximum length of the hammer. For the 16 lb. through 5 kg implements it must be at least 117.5 cm and not more than 121.5 cm from the inside of the grip to the end of the head. IAAF has modified the 5 kg length to 116.5 cm to 120.0 cm. For 4 kg and 3 kg implements, the measurements are 116 cm and 119.5 cm. When you do this make sure the wire is straight but not stretched and not curled. The weight of the hammer itself is usually not enough to straighten the wire, particularly if the wire has been curled from normal use or for transport. You may need to apply additional tension. Be careful not to apply too much tension so that you stretch the wire, the wire loops, or bend the handle. If you are using the hammer stretcher, be careful to make sure the handle and ball are properly placed so that they won't come loose as you increase tension. Tighten until the wire it is reasonably taut but not enough to bend the handle. When taut use the gauge to check the maximum and minimum lengths. Be careful in doing this measurement. If you are using the TRACKMASTER^(TM) or Gill hammer stand, we recommend you use a "C" clamp to hold it firmly to the table surface.

3. Check the weight. This is most easily done by placing the handle on the scale and then putting the head in the handle so it doesn't roll. Make sure the wire doesn't hit anything in the process. The open men's hammer weight is 7.260 kg (16 lb.) and the women's is 4 kg. If you are using the TRACKMASTER^(TM) the weights are 1, 4, and 8 for Men's and 7 for Women's hammer. See appendix or rule books for other weights.

4. Check the hammer head diameter and roundness. The hammer should be essentially spherical. It must pass in at least three different planes. If it doesn't pass, impound it. It must be at least 110 mm and not more than 130 mm in diameter. For the 4 kg hammer the diameter measurements are 95 and 110 mm. Note for other weight hammers check the shot dimensions since they are the same.

Note: 1: There is currently no quantitative check for out of roundness or sphericity, a flat spot etc. What is round to me may not be round to someone else. Roundness for the hammer is less important than for the shot since you don't grip the hammer by the head. Likewise you do an eccentricity test in item 5.

5. Check the center of gravity by placing on 12 cm sharp edge orifice. It passes if it doesn't fall off.

6. Check the wire diameter in at least three places. If it is close or there appears to be a significant amount of wire draw then impound the implement unless the athlete can change the wire and resubmit the implement. The wire should be a single unbroken length of spring wire at least 3 mm in diameter. The most likely places for breaks are where the wire is wound around itself to form the loops at both ends. Likewise any sharp kinks are potential problem areas. The wire is connected to the head by a swivel and the grip or handle by a loop but not a swivel.

7. Check the size of the loops at both ends of the wire, neither can be bigger than 1.95 cm in USA Track & Field meets. This dimension is not specified by other rules

NOTE: Why check the loop? Some competitors will come with a big loop and during warm ups it will straighten out making the hammer too long. This has been a parameter in the USATF rulebook for a number of years but it is not covered in the others. Also check to make sure the wire loop is tight so that it won't become unraveled when throwing. If appropriate you may need to add adhesive tape over the ends to keep it from unraveling and or so the wire ends don't get caught in the cage netting. This is a safety concern rather than an implement weight concern.

8. Check the dimensions of the handle. Currently they should be not more than 130 mm in inside width and 110 mm from edge of loop to lower edge of loop for connecting the wire.

9. If the implement passes then mark it by spraying both the loops and the connection points so that neither the handle nor the wire can be changed. Mark the swivel plug so that it can't be turned to lengthen the hammer. Alternatively wrap both with a colored tape. This is especially useful on days when the landing area is wet, since it lasts longer than paint, which tends to come off.

WEIGHT:

1. For safety check the weight head and handle for dents or cracks that might cause them to break during competition and be sure the plug for adjusting the weight is tight. If there is a plug nut then seal or mark it per shot instructions. Make sure the head is essentially spherical and made of iron or other metal not softer than brass. Check the embedded forged steel eye used for attachment. In some indoor competitions a weight bag or synthetically covered weight may be used. Typically a synthetically cover sphere (which can have internal movement) is contained in a canvas bag which is attached to a handle (See NCAA Rule 10-9 for a picture).

2. Check the weight. This is most easily done by placing the handle on the scale and putting the head in the handle so it doesn't roll. The weights for this event are measured in lb. If you are using the TRACKMASTER^(TM) you can use weights 6, 7, 8 and 9 for the 35 lb. weight. The number 9 weight is optional. The men's weight is 35 lb. (15.880 kg) and the women's is 20 lb. (9.080).

3. Check the maximum length of the weight. It must be no more than 406.5 mm from the inside of the longest leg of the grip to the end of the head. This is true for both the metal weight and the weight bag. When you do this make sure the links are straight and not curled. Be careful in doing this measurement. If you are using the TRACKMASTER^(TM) hammer stand, we recommend you use at least a "C" clamp to hold it to the table surface so it doesn't tip. We also recommend a slight alteration to remove the center extension and add a calibration to the upper leg for ease of measurement.

4. Check the triangular shape of the handle and its diameter at a minimum of three places. It should be at least 12.7 mm in diameter and not more than 184.1 mm on a side inside the handle. If it does not meet the minimums impound the implement unless the athlete can change the handle and resubmit the implement. The handle should not stretch appreciably under the weight of the implement. The NCAA now specifies that a hammer handle cannot be used and if the grip has the ability to turn within its connection point to the ball or bag, it shall be an equilateral triangle with no side exceeding 190mm or 7.5 in nor less than 100 mm or 4 in. If the grip cannot turn, it only needs to be a triangle with the same maximum and minimum dimension requirement.

5. Check that the minimum diameter of the welded steel links making up the connector is 9.5 mm. Note there is currently some wording difference between the NCAA and the USATF rule book. There is no intent that the rules be different. The NCAA also allows the grip to be connected to the ball by means of a steel line.

6. The 35 lb. implement has a minimum diameter of 145 mm and a maximum diameter of 165 mm. The 20 lb. implement has a 130 mm minimum and a 150 mm maximum. If they are synthetically covered spherical implements, they can be no greater than 15 mm larger in diameter than the corresponding metal implement. Weight bags have no diameter requirement. See Tables in appendix for other implements.

7. Beginning in 1999, there is now a center of gravity measurement for the weight for USATF. If a filling is used, it must be inserted in such a manner that it is immovable and the center of gravity shall be not more than 9 mm from the center of the sphere. This can be check in a manner similar to the hammer.

8. If the implement passes, then mark it by spraying both the loops or tape them and the connection points so that neither the handle nor the connectors can be changed.

JAVELIN:

NOTE: The javelin has the most required measurements so it is very important that the order shown be used in order to minimize doing measurements on an implement that won't pass. The most common reasons for failure are listed first.

1. Hold the javelin vertically, tip down then rotate it so the point is up and shake it. Listen for any internal movement. You may need to tap it on the floor to make sure there aren't any moveable parts. This might impact the center of gravity and therefore the flight characteristics of the implement.

2. Take the javelin by the whipcord to see if it is damp to help it make weight. If it is, impound it.

3. Check the overall length, the length of the head and the length of the grip. You can easily make a folding device to measure the overall length and the incremental distances as shown in the equipment section. Alternately you can mark a retractable steel tape or adhesive tape on the edge of a table with the necessary dimensions. This allows you to quickly lay the javelin on it and check the overall length, the length of the point, and length of the grip. You can also mark the 150 mm tip and tail marks used later for contour measurements. See the table in the Appendix for all the appropriate dimensions for each of the currently legal javelins.

4. Check the center of gravity by performing the balance test. Balance the javelin at about the second cord on the handle. The javelin should just balance or just drop down at the point. This is the most common reason for why a javelin fails. Mark the center of gravity, usually about one or two cords back from the front of the grip. Measure the distance to the tip. See table of dimensions in Appendix. Check for indentations, rings, roughness, flutes or other aerodynamic improvements, i.e. non-smooth finish. Normal wear is acceptable as long as groves aren't symmetric. There should be no tape or decals on the javelin that might improve the aerodynamics during flight. If the balance is very close, make sure that there isn't any paint or solder on the tip that might come off during the competition and change the balance point. You can use nail polish remover to remove the paint and retest the javelin.

5. Check the weight. If you are using the TRACKMASTER^(TM) then use the number 1 weight for the men's javelin and no weight for the women's javelin. There is no weight for the 400 g javelin. If you have a 200 g weight you can add it to the pan and use the balance (200 g + 400 g Javelin = 600 g). If you need to do the other javelins you will need other weights.

6. Check the tip to see if it meets the maximum of forty-degree taper using the tip guide. This can also be done with a plastic protractor and several pieces of tape.

The remaining checks should be made whenever possibly but generally don't change much with used, i.e. they are characteristic of the javelin manufacturing process. Thus if you know they have been previously checked because your mark or one you recognize is on the javelin then if you have limited time you can skip them. The first time you see a javelin each year you might want to check these and use a special mark to indicate that you have checked them so that you can skip these steps for the rest of the year.

7. Check the maximum diameter. This is specified to be just in front of the grip. The diameter behind the handle should be at least (a minimum) the maximum diameter less 0.25 mm in NCAA, USATF and IAAF meets. The most accurate way to do this is with the calipers. When using the calipers don't push too hard. Just snug it up and move it around to get the maximum dimension at that point. Record that. The diameter at the rear of the grip should be at least as large as the maximum diameter less 0.25 mm. Note it is not uncommon for it to be slightly larger. Check the diameter of the tail, which must be greater than 3.5 mm for all javelins. Check the diameter of the grip. The difference between the diameter of the grip and the diameter of the shaft at the point at the front of the grip is 8 mm. The diameter just behind the head should be at least the head diameter at that point less 2.5 mm. There can be no abrupt alterations along the shaft. Note if you have one of the older TRACKMASTER^(TM) ring sets, they will not measure the new javelins properly. You can order a new set from TRACKMASTER^(TM). In the interest of time, some of these measurements may be excluded if a visual check does not show a gross or obvious problem.

8. Mark the 150 mm point from the tip and the tail (125 mm for the 400g javelin). Mark the mid-point between those points and the center of gravity. Make the necessary measurements using either the TRACKMASTER^(TM) gauge or a caliper. The percent of the total diameter for both the Men's and Women's javelin are the same. The diameter at the 150 mm point from the tip will be less than or equal to 80% of the maximum diameter. The diameter at the 150 mm point from the tail must be greater than 40% of the maximum diameter. The diameter at the mid-point between the 150 mm to the center of gravity before the grip will be less than or equal to 90 percent of the total diameter. The equivalent point half way to the tail will be a greater than or equal to 90% of the maximum diameter. Note: Using the rings from the older TRACKMASTER^(TM) sets will not work with the new javelins.

9. Use a 50 cm long straight edge to check uniform tapering if there seems to be a question.

10. If the javelin passes all the tests, mark it on either near the whip cord or just above the metal head.

Because of the many changes in specifications in javelins over the last 16 years the following table of older javelin specifications is included. You will continue to see some of these implements at meets for the next few years. This table will help you verify what they are. All the dimensions shown are in millimeters. Note although there have been several changes to the Masters' 400 g javelin over the last ten years to make it more aerodynamic and easier to manufacture there has not been the formal demarcation of specs like occurred with the open 800 and 600 g javelins.

HISTORICAL JAVELIN SPECIFICATIONS

Measurement/Group		High School	IAAF	IAAF	High School	IAAF
		Pre 2002	Pre 1992	Pre 1999	Pre 2002	Pre 1986
Users		Girls	Open	Open	Boys	Open
Weight, g		600	600	600	800	800
Length of Javelin	Min.	2200	2200	2200	2600	2600
	Max.	2300	2300	2300	2700	2700
Length of Head	Min.	250	250	250	250	250
	Max.	350*	330	330	350*	330
Length of Rubber Tip	Min.	35			35	
	Max.	77			77	
Diam. of Front of Rubber Tip	Min.	14			14	
	Max.	35			35	
Thickness at Front of Rubber Tip	Min.	5			5	
Length of Grip	Min.	140	140	140	150	150
	Max.	150	150	150	160	160
Length from Tip to	Min.	800	800	800	900	900
	Max.	950	950	950	1100	1100
Diameter of Shaft (D)	Min.	20	20	20	25	25
	Max.	25	25	25	30	30
Diam. Reduction Front to Back of Grip	Max.	-	0.25	0.25		0.25
Diam. Reduction behind Head	Max.	-	2.5	2.5	-	2.5
Diam. at mid point CG to Tip	Max.	-	0.9D	0.9D	-	0.9D
Diam. at mid point CG to Tail	Min.	-	0.7D	0.9D	-	0.9D
Diam. 150 mm from Tip	Max.	-	0.8D	0.8D	-	0.8D
Diam. 150 mm from Tail	Min.	-	0.3D	0.4D	-	0.8D
Diam. 125 mm from Tip	Max.					
Diam. 125 mm from Tail	Min.					
Diam. of Tail	Min.	-	3.5	3.5	-	3.5
Diam. of Grip	Max.		D+8mm	D+8mm		D+8mm
Circumference of Grip over Diam.	Max.	D+1 in			D+1 in	
Diam. at mid point fm front of grip to Tip	Max.					
Diam. at mid point fm front of grip to Tail	Max.					
Angle of Tip	Max.		40°	40°		40°

*When a rubber tip is used, the metal point shall be 70 mm shorter than the normal point, and shall end (before affixing the rubber tie) in a slightly rounded button shape 18-21 mm in diameter for the boy's 800g and 16-18 mm in diameter for the girl's 600 g. The length and center of gravity with the rubber tip in place is 6 cm less than the standard javelin with a metal point.

Mini Javelin:

In 2000 the Youth Committee adopted the 300 gram mini javelin for use with the younger age groups. Other than weight all three sizes have the same specifications. The shaft, grip and fins will be made out of plastic; the tip shall be made of soft rubber with a blunt, rounded tip. The fins must be smooth.

Name	300g	400g	500g
Nominal Wt. G	300	400	500
Minimum Record Wt. g	300	400	500

The following specifications are common to all mini javelins:

MINI JAVELIN (All Weights)	
Overall Length min. mm	685
Overall Length max. mm	705
Length of Head min. mm	84
Length of Head max. mm	94
Tip Diameter at largest point, min. mm	37
Tip Diameter at largest point, max. mm	43
Distance from tip to CG min. mm	365
Distance from tip to CG max. mm	380
Diameter of Shaft forward of grip min. mm	30
Diameter of Shaft forward of grip max. mm	38
Diameter of Shaft behind grip min. mm	24
Diameter of Shaft behind grip max. mm	30
Diameter of Shaft at grip min. mm	34
Diameter of Shaft at grip max. mm	40
Width of grip min. mm	99
Width of grip max. mm	109
Location of front of grip from tip of tail min. mm	322
Location of front of grip from tip of tail max. mm	332
Number of Fins	4
Fin Length min. mm	162
Fin Length max. mm	168
Fin diameter (peak to peak opposing fins) min. mm	95
Fin diameter (peak to peak opposing fins) max. mm	105

Note: Currently the TurboJav™ is the only javelin that meets these specifications although other manufactures will begin making them.

1. You need to check each dimension. Because of the fins finding the center of gravity requires a much higher balance point. Most dimensions are easily measured with a 15 or 30 cm (6-12 inch) straight edge and the diameters with a caliper. The only other specifications are weight and center of gravity. Alternately you can mark your javelin board with the required dimensions and get a larger fulcrum to determine the center of gravity.

USE OF THE TRACKMASTER^(TM):

The following section is included as an introduction the TRACKMASTER^(TM) or Gill Implement Certification equipment. It is the most commonly used weights and measure system in the United States. However, the TRACKMASTER^(TM) does not perform all the indicated tests listed in the measurement section. You may have to construct or buy some additional devices to do the measurements. Most are reasonably straight forward. If you have access to either a wood shop or a metal shop you can make your own. Use a caliper to make sure it is accurate, to at least 0.1%.

Generally both the TRACKMASTER^(TM) and Gill kit are set up on the principle of pass or fail. It doesn't give you the actual measurement but indicates that you are above the minimum or below the maximum. The TRACKMASTER^(TM) is the most widely used system with over 350 units through out the United States. Before 1997, there were four models sold. Mark I for Men, Mark II for Women, Mark III for Men, Women and Junior, and Mark IV for High School. Gill began sales in 2000. Instructions come with each system but the following is a more detailed description of what the tests are for and how they should be performed and interpreted.

The following is a list of the gauges included in each of the m TRACKMASTER^(TM) models:

Gauge/Test Device USE	MARK I Men	MARK II Women	MARK III Men Women Junior	MARK IV High School
Scale	X	X	X	X
Tip Weight for Men Implement	X		X	
Tip Weight for Women Implement		X	X	
Tip Weights for Junior Implement			X	X
Tip Weights for 35 lbs.	Opt.		Opt.	
Shot/Hammer Diam.. Gauge 130 mm	X		X	
Shot/Hammer Diam. Gauge 110 mm	X	X	X	
Shot/Hammer Diam. Gauge 95 mm		X	X	
Javelin Grip Gauge Men	X		X	
Javelin Grip Gauge Women		X	X	
Javelin Balance/Tip Gauge	X	X	X	
Javelin Diameter Gauge	X	X	X	
Discus Center Plate Gauge	X	X	X	
Discus Diam./Thickness Men	X		X	
Discus Diam./Thickness Women		X	X	
Discus Diam./Thickness Junior				
Hammer Length Gauge	X	X	X	
Hammer Balance Tester	X	X	X	
Hammer Wire Diam. Caliper	X	X	X	
Carrying Case	X	X	X	X
Overall Weight lb.	28	33	41	27

Note: You can order a number 9 tip weight which when combined with numbers 6,7, and 8 will allow you to do the 35 lb. weight. You can also get a #10 weight for the 6 lb. shot. But the TRACKMASTER^(TM) does not contain the equivalent of the 5 kg weight used in Masters' events.

The new version models since June, 1997 have an electronic scale and several additional improvements as seen below:

Items Included	Mark V	Mark VI	Mark VII	Mark VIII	Mark IX	Mark X
Electronic Scale	X	X	X	X	X	X
Carrying Case	X	X	X	X	X	X
Hammer Gauge	X	X	X	X		
Javelin Diameter Gauge	X	X	X	X		
Javelin Tip and Grip Gauge	X	X	X	X		
Javelin Balance Gauge	X	X	X	X		
Men's Discus Gauge	X	X	X			
Women's Discus Gauge	X	X	X	X	X	
1.5 & 1.6 Discus Gauge	X	X		X	X	
Calipers and Square	X	X	X	X		
Shot Rings - 85 mm (purchase separately)	X					
Shot Rings - 95 mm	X	X			X	
Shot Rings - 98.4 mm (HS)	X	X		X	X	
Shot Rings - 100 mm	X					
Shot Rings - 105 mm	X					
Items Included	Mark V	Mark VI	Mark VII	Mark VIII	Mark IX	Mark X
Shot Rings - 110 mm	X	X	X	X	X	
Shot Rings - 115 mm	X					
Shot Rings - 117.5 mm (HS)	X	X		X	X	
Shot Rings - 125 mm	X					

Shot Rings - 130 mm	X	X	X			
Shot Rings - 145 mm	X					
Instruction Manual	X	X	X	X	X	X

Some of the most common complaints about this equipment are:

1. Initial Cost is high
2. Cost of Maintenance is high
3. Old models have not all been updated with improvements
4. Instructions are not current with rule changes
5. Owners Neglect leads to inaccurate measurements
 - a> Equipment gets wet and isn't properly dried, and cleaned.
 - b> Instructions get lost.
 - c> Equipment gets lost.
 - d> Equipment gets damaged.
 - e> Scale not accurate, or impossible to calibrate
 - f> Every scale responds differently with different accuracy.
 - g> Scale can not be calibrated for the "heavy end" of weights.

USE OF OTHER METHODS:

If you know of other methods that should be discussed please pass them along to the editor at 5104 Alhambra Valley Road, Martinez, Ca. 94553-9775, 510-229-2927 or e-mail george_kleeman@comcast.net.

IMPORTANT WEIGHTS AND MEASURES DIFFERENCES BETWEEN THE VARIOUS RULEBOOKS AND DIVISIONS:

Tables 1 -4 in the appendix summarizes all of specifications for all implements. Some data is still needed for the handicap implements. This table was compiled as convenient way to have all the data in one place. In case of a question always refer to the rulebook itself in the event that a table has an incorrect entry.

Weight: There are still some slight difference between the NCAA and USATF concerning the Weight specifications.

Javelin: There no longer any differences between the NCAA, USATF, WMA and IAAF for the javelin specifications.

APPENDIX

	Page
INDEX	24
W&M Room Layout	25
Sample Implement Inspection & impoundment Form	26
Implement Specifications Summary Tables	27
Hammer & Weight/Superweight	27
Shot & Dicus	28
Javelin	29
Mini Javelin	30



W&M ROOM LAYOUT

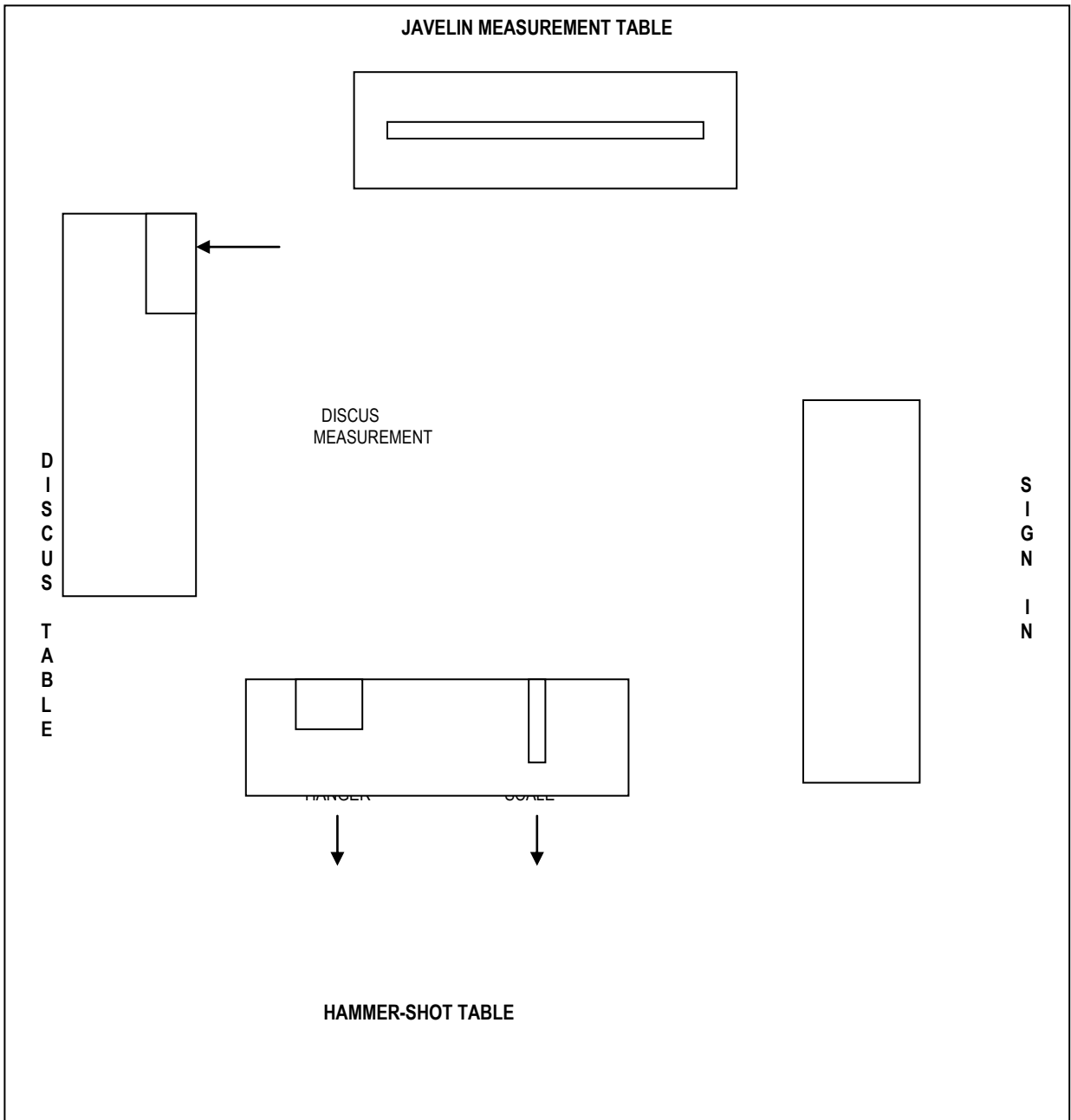



WEIGHTS AND MEASURES

IMPLEMENT INSPECTION & IMPOUNDMENT RECORD

MEET _____ DATE _____ INSPECTOR _____ MARK _____

← COMPLETE THESE COLUMNS →

N O.	NAME	SCHOOL /CLUB	IMPLEMENT (Circle Name & Sex)	MAKE/	C/I	REASON	SIGNATURE FOR
				MODEL		IMPOUNDED	
1			SDH JW M F				
2			SDH JW M F				
3			SDH JW M F				
4			SDH JW M F				
5			SDH JW M F				
6			SDH JW M F				
7			SDH JW M F				
8			SDH JW M F				
9			SDH JW M F				
10			SDH JW M F				
11			SDH JW M F				
12			SDH JW M F				
13			SDH JW M F				
14			SDH JW M F				
15			SDH JW M F				
16			SDH JW M F				
17			SDH JW M F				
18			SDH JW M F				
19			SDH JW M F				
20			SDH JW M F				
21			SDH JW M F				
22			SDH JW M F				
23			SDH JW M F				
24			SDH JW M F				
25			SDH JW M F				
26			SDH JW M F				
27			SDH JW M F				
28			SDH JW M F				
29			SDH JW M F				
30			SDH JW M F				



TABLE 1

THROWING IMPLEMENT SPECIFICATIONS SUMMARY

HAMMER / WEIGHT/ SUPERWEIGHT

HAMMER								
USATF RULE: 200	UNITS							
IMPLEMENT NAME:		16 LB	6 KG	12 LB	5 KG	4 KG	3 KG	
AGE GROUP:								
OPEN:		MEN				WOMEN		
MASTERS:		M30-M45	M50-M55		M60-M65	M70-M75	M80+	
						W30-W45	W50-	
JUNIORS:			MEN	HS		WOMEN		
WEIGHT:	NOM.-LB	16.00	13.23	12.00	11.02	8.82	6.61	
	NOM. LB-OZ	16-0	13-3.6	12-0	11-0.3	8-13	6-9.8	
	NOM. KG	7.26	6.00	5.44	5.00	4.00	3.00	
	MIN. RECORD	7.260	6.000	5.443	5.000	4.000	3.000	
RANGE FOR SUPPLY:	MIN KG	7.265	6.005	5.450	5.005	4.005	3.005	
	MAX KG	7.285	6.025	5.475	5.025	4.025	3.025	
DIAMETER:	MIN MM	110	105	98.4	100	95	85	
	MAX MM	130	125	117.5	120	110	100	
OVERALL LENGTH:	MIN MM	1175	1175	1175	1165	1160	1160	
	MAX MM	1215	1215	1215	1200	1195	1195	
WIRE DIAMETER:	MIN MM	3.0	3.0	3.0	3.0	3.0	3.0	
CENTER OF GRAVITY (OFF CENTER EXCEPT FOR WAVA)	MAX MM	6	6	6	6	6	6	
INTERNAL MOVEMENT:		NONE	NONE	NONE	NONE	NONE	NONE	
HANDLE)	MM	130Wx110L	130Wx110L	130Wx110L	130Wx110L	130Wx110L	130Wx110L	
LOOP DIAMETER: (USATF ONLY)	MAX MM	19.5	19.5	19.5	19.5	19.5	19.5	

WEIGHT/SUPERWEIGHT								
USATF RULE: 201	UNITS							
IMPLEMENT NAME:		56 LB	44 LB	35 LB	25 LB	20 LB	16 LB	12 LB
AGE GROUP:								
OPEN:		MEN		MEN		WOMEN	WOMEN	
MASTERS WEIGHT:				M30-M45	M50-M55	M60-M65	M70-M75	M80+
						W30-W45	W50-W55	W60+
SUPERWEIGHT		M30-M55	M60-M65	M70-M75	M80+			
				W30-W45	W50-W65	W70+		
WEIGHT:	NOM. LB	56.00	44.00	35.00	25.00	20.00	16.00	12.00
	NOM. KG	25.40	20.00	15.88	11.34	9.08	7.26	5.45
	MIN. RECORD	25.400	20.000	15.880	11.340	9.080	7.260	5.450
RANGE FOR SUPPLY:	MIN. KG	25.405	20.005	15.885	11.345	9.085	7.265	5.455
	MAX. KG	25.425	20.025	15.905	11.365	9.105	7.285	5.475
OVERALL LENGTH:	MAX MM	406.4	406.4	406.4	406.4	406.4	406.4	406.4
WMA	MAX MM			410.0	410.0	410.0	410.0	410.0
HANDLE (TRIANGULAR):	MAX MM	< 184 /SIDE	< 184 /SIDE	< 184 /SIDE	< 184 /SIDE	< 184 /SIDE	< 184 /SIDE	< 184 /SIDE
CENTER OF GRAVITY:	MAX MM			9	9	9	9	9
OFF CENTER (WAVA ONLY)								
DIAMETER:	MIN MM	-	-	145	130	120	110	100
	MAX MM	-	-	165	150	140	130	120
INDOOR DIAMETER WMA	MAX MM	-	-	180	165	155	145	135

Footnotes: Internal movement allowed in USATF and NCAA Indoor implements. No internal movement (i.e. solid sphere) for outdoor implement.

WMA does not allow internal movement in either indoor or outdoor implements.

For **Ultraweight implement specs** see USATF rulebook, Rule 195. There are very few specs other than weigh and maximum length of 15.24 cm and Rule 202.

For NCAA meets accept the 20 and 35 lbs weights if they meet the imperial weight even if slightly below the metric equivalent.



TABLE 2 THROWING IMPLEMENT SPECIFICATIONS SUMMARY SHOT / DISCUS

SHOT										
USATF RULE: 202	UNITS									
IMPLEMENT NAME:	NOMINAL	16 LB	6.25 KG	6 KG	12 LB	5 KG	4 KG	3 KG	6 LB	2 KG
AGE GROUP:										
OPEN:		MEN					WOMEN			
MASTERS:		M30-M45		M50-M55		M60-M65	M70-M75	M80+		
							W30-W45	W50+		
JUNIORS:				MEN	HS		WOMEN			
YOUTH:					Y MEN		Y WOMEN		BANTAM	
					INTERM B		INTERM G		MIDGET	
					HS BOYS		YOUTH B		YOUTH G	
							HS GIRLS			
WEIGHT:	NOM. LB	16.00	13.78	13.23	12.00	11.02	8.82	6.61	6.00	4.41
	NOM. LB-OZ	16-0	13-12.5	13-3.7	12-0	11-0.3	8-13	6-10.6	6-0	6-6.5
	NOM. KG	7.26	6.25	6.00	5.44	5.00	4.00	3.00	2.72	2.00
	MIN. RECORD	7.260	6.250	6.000	5.443	5.000	4.000	3.000	2.720	2.000
RANGE FOR SUPPLY:	MIN KG	7.265	6.255	6.005	5.450	5.005	4.005	3.005	2.725	2.005
	MAX KG	7.285	6.275	6.025	5.475	5.025	4.025	3.025	2.745	2.025
DIAMETER:	MIN MM	110	105	105	98.4	100	95	85	-	-
	MAX MM	130	125	130	117.5	120	110	110	-	-
MEN WMA	MAX MM	130		125		120	120	110		
USATF INDOOR IMPL. ONLY:	MAX MM	145		145		135	130	130		
CIRCUMFERENCE HS ONLY:	MIN MM				309.1		298.4			
	MAX MM				369.1		345.6			

DISCUS								
USATF RULE: 203	UNITS							
IMPLEMENT NAME:		2 KG	1.75 KG	1.6 KG	1.5 KG	1.0 KG	0.75 KG	
AGE GROUP:								
OPEN:		MEN				WOMEN	WOMEN	
MASTERS:		M30-M45			M50-M55	M60-M95		
						W30-W75	W80+	
JUNIORS:			MEN			YOUTH		
YOUTH:				INTERM B		INTERM G		
				Y MEN		Y WOMEN		
WEIGHT:	NOM. LB	4.41	3.86	3.53	3.31	2.20		
	NOM. KG	2.00	1.75	1.60	1.50	1.00	0.75	
	MIN.	2.000	1.750	1.600	1.500	1.000	0.750	
RANGE FOR SUPPLY:	MIN KG	2.005	1.755	1.605	1.505	1.005	0.755	
	MAX KG	2.025	1.775	1.625	1.525	1.025	0.775	
DIAMETER:	MIN MM	219	210	209	200	180	166	
	MAX MM	221	212	211	202	182	169	
CENTER:	MIN MM	50	50	50	50	50	50	
	MAX MM	57	57	57	57	57	57	
THICKNESS AT CENTER PLATE:	MIN MM	44	41	40	38	37	33	
	MAX MM	46	43	42	40	39	37	
THICKNESS RIM 6MM IN:	MAX MM	13	13	13	13	13	13	
THICKNESS RIM 6MM IN:	MIN MM	12	12	12	12	12	10	

Change in bold.



TABLE 3 THROWING IMPLEMENT SPECIFICATIONS SUMMARY JAVELIN

JAVELIN								
USATF RULE: 206	UNITS							
IMPLEMENT NAME:		800 G	800 G	700 G	600 G	600 G	500 G	400 G
AGE GROUP:		POST 86				POST 98		
OPEN:		MEN NCAA				WOMEN NCAA		
MASTERS:		M30-M45		M50-M55	W30-W45 M60-M65		W50-W55 M70-M75	M80+ W60+
JUNIORS:		MEN			WOMEN			
YOUTH:				IAAF BOYS	YOUTH			
		INTERM			INTERM			
		Y MEN			Y WOMEN			
HIGH SCHOOL:			HS BOYS ^c			HS GIRLS ^c		
WEIGHT:	NOM. G	800	800	700	600	600	500	400
	NOM. OZ	28.22	28.22	24.69	21.16	21.16	17.64	14.11
	MIN. RECORD	800	800	700	600	600	500	400
RANGE FOR SUPPLY:	MIN G	805	805	705	605	605	505	405
	MAX G	825	825	725	625	625	525	425
LOCATION OF MAX. DIAMETER:	GRIP	FRONT	FRONT	FRONT	FRONT	FRONT	FRONT	FRONT
DIAMETER AT THICKEST POINT:	MIN MM	25	25	23	20	20	20	20
	MAX MM	30	30	28	25	25	24	23
DIAM REDUCTION AT REAR OF GRIP	MAX MM	0.25	0.25	0.25	0.25	0.25	0.25	0.25
OVERALL LENGTH:	MIN MM	2600	2600	2300	2200	2200	2000	1850
	MAX MM	2700	2700	2400	2300	2300	2100	1950
LENGTH OF HEAD:	MIN MM	250	250	250	250	250	220	200
	MAX MM	330	330	330	330	330	270	250
DIST. FROM TIP TO CENTER GRAVITY:	MIN MM	900	900	860	800	800	780	750
	MAX MM	1060	1060	1000	920	920	880	800
WIDTH OF GRIP:	MIN MM	150	150	150	140	140	135	130
	MAX MM	160	160	160	150	150	145	140
OVER MAX SHAFT DIAM @ GRIP:	MAX MM	8	8	8	8	8	8	8
CIRC. OVER SHAFT @GRIP:	INCH		<1			<1		
DIAMETER VARIATION:	MAX %	<2%	<2%	<2%	<2%	<2%	<2%	<2%
DIAM @ 125 MM FROM TIP:	MAX %							=<80%
DIAM @ 150 MM FROM TIP ^a :	MAX %	=<80%	=<80%	=<80%	=<80%	=<80%	=<80%	
DIAM BEHIND HEAD-DIAM OF HEAD	MM MAX	=<2.5	=<2.5	=<2.5	=<2.5	=<2.5	=<2.5	=<2.5
DIAM @ MIDPOINT FROM CG TO TIP ^a :	MAX %	=<90%	=<90%	=<90%	=<90%	=<90%	=<90%	=<90%
DIAM R MIDPOINT FROM CG TO TAIL ^a :	MIN %	=>90%	=>90%	=>90%	=>90%	=>90%	=>90%	=>90%
DIAM REAR AT 125 MM ^a :	MIN %							=>40%
DIAM REAR AT 150 MM ^a :	MIN %	=>40%	=>40%	=>40%	=>40%	=>40%	=>40%	
DIAM AT TAIL ^a :	MIN MM	=>3.5	=>3.5	=>3.5	=>3.5	=>3.5	=>3.5	=>3.5
TIP ANGLE	MAX DEG	=<40	=<40	=<40	=<40	=<40	=<40	=<40

NOTE: CONVERSIONS 2.20462 LBS PER KG/ 16 OZ PER LB/ 453.5924 G PER LB /28.34953 G PER OZ

- Footnote: a) The Trackmaster™/Gill gauge should pass beyond the mark since it is a “shall not exceed” dimension; i.e., less than or equal to this measurement.
b) The Trackmaster™/Gill gauge should not pass beyond the mark since it is a “shall exceed” dimension; i.e., greater than or equal to this measurement.
c) If use a rubber tip then there are alternate specifications (see the javelin section or Rule 6-5-2 in High School Rules) This javelin should meet all IAAF specs. Not all are shown in the HS rulebook but they do apply. When using a rubber tip (or soft plastic) the metal point shall end before affixing the rubber tip in a slightly rounded button-shape 18-21 mm in diameter for the boy's javelin and 16-18 mm in diameter for girl's javelin. Overall length of rubber tip 35-77 mm. Diameter at front of the tip is 14-35 mm and thickness at front of tip is 5 mm minimum.



The Mini Javelin was new for 2001. The shaft, grip and fins shall be made out of plastic. The tip shall be made of soft rubber with a blunt, rounded end. The nominal and minimum weights shall be 300g, 400, and 500g. Only the **300g implement** has been **approved for use in Youth meets**. The fins will be flat and smooth i.e. no flutes or bends and shall be perpendicular to the surface of the javelin. All shall conform to the following specifications:

MINI JAVELIN (All Weights)	
Overall Length min. mm	685
Overall Length max. mm	705
Length of Head min. mm	84
Length of Head max. mm	94
Tip Diameter at largest point, min. mm	37
Tip Diameter at largest point, max. mm	43
Distance from tip to CG min. mm	365
Distance from tip to CG max. mm	380
Diameter of Shaft forward of grip min. mm	30
Diameter of Shaft forward of grip max. mm	38
Diameter of Shaft behind grip min. mm	24
Diameter of Shaft behind grip max. mm	30
Diameter of Shaft at grip min. mm	34
Diameter of Shaft at grip max. mm	40
Width of grip min. mm	99
Width of grip max. mm	109
Location of front of grip from tip of tail min. mm	322
Location of front of grip from tip of tail max. mm	332
Number of Fins	4
Fin Length min. mm	162
Fin Length max. mm	168
Fin diameter (peak to peak opposing fins) min. mm	95
Fin diameter (peak to peak opposing fins) max. mm	105

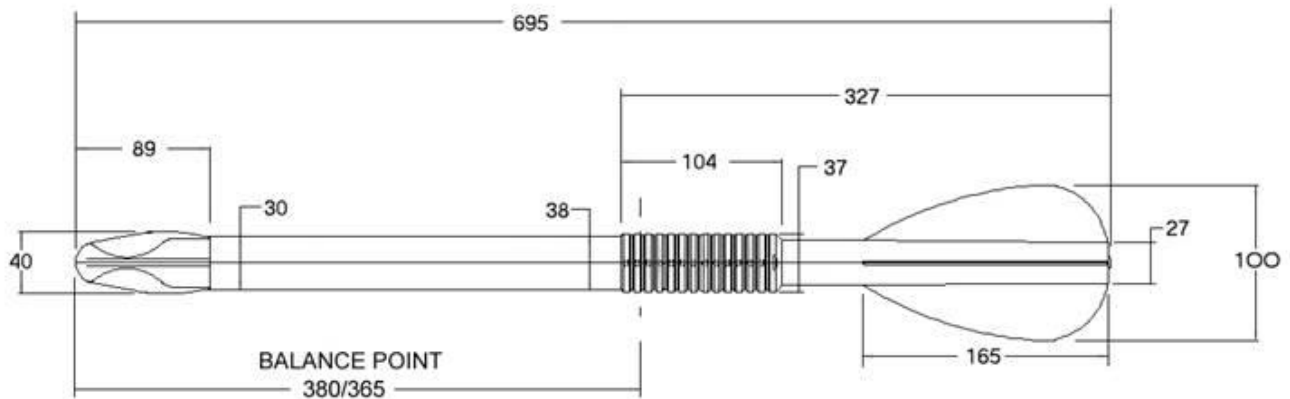



WEIGHTS AND MEASURES HANDBOOK APPENDIX

**FOR THE
PACIFIC ASSOCIATION
UNITED STATES TRACK & FIELD**

Appendix to the USATF Equipment and Facilities
Specification Subcommittee's Weights and Measures Handbook

Author and Editor: George Kleeman

PRICE \$1.00

January, 2007



TABLE 4 THROWING IMPLEMENT SPECIFICATIONS SUMMARY MINI JAVELIN

INDEX:

	Page
INDEX	1
INTRODUCTION	1
HOW TO BECOME A CERTIFIED OFFICIAL	2
PREMEET REQUIREMENTS	2
Equipment	2
Differences in Equipment	2
WEIGHTS AND MEASURES TOOLS FROM THE PACIFIC ASSOCIATION	4
Scale Weights	4
Javelin Board	5
Pacific Assoc. Tool Box Index	6
Other Measuring Devices	6
GENERAL PROCEDURE FOR ALL IMPLEMENTS	7
Shot	7
Discus	7
Hammer	7
Weight	8
Javelin	8
Use of other Methods	8

INTRODUCTION:

This manual was prepared for the use, education and training of Inspectors of Implement in the Pacific Association. Besides dealing with general procedures, it was specifically written to train local officials how to use the implement measurement equipment available from the Pacific Association Equipment Committee and used at Stanford and the University of California at Berkeley. This manual is an appendix to the latest version of the national manual for Weights and Measures Officials, which was developed by the author for the Equipment and Facilities Specifications Subcommittee of the Officials Committee of USA Track and Field. This manual covers only variation use in the Pacific Association and the specialized Pacific Association equipment. Additional copies of both manuals are available by sending \$3.00 for each copy to George Kleeman, 5104 Alhambra Valley Road, Martinez, Ca 94553-9773, 925-229-2927 to cover the cost of postage and reproduction. Comments and recommendations are welcome and can be sent to the same address or via e-mail at george_kleeman@comcast.net. These manuals are the first known publication of how to do the job of an Implement Inspector. In addition to these manuals there is available a free newsletter for Weights and Measures Officials across the country, published by the subcommittee. To get on the mailing list write to the same address or e-mail with your request.

This manual is intended as a "how to" book for the novice Inspector of Implements as well as a guide to the seasoned veteran. It is an attempt to get more uniformity in the methods used to certify implements and in the measurement techniques being used throughout the United States.

Although the specifications for implements are published in the various rule books of the various governing bodies for Track and Field, the method of weighing and measuring implements is not specified in any of them. The Inspector of Implements should be able to say that any implement passes because it met every requirement of the rules governing the meet. Only weighting an implement does not approve it for use in competition. It must meet all the measurement standards.



TABLE 4 THROWING IMPLEMENT SPECIFICATIONS SUMMARY MINI JAVELIN

HOW TO BECOME A CERTIFIED OFFICIAL:

At the present time USA Track & Field is the major certifier of officials for track and field. As the national governing body for Athletics in the United States, which includes the sports of Track and Field, Race Walking, Cross Country and Long Distance Running, it is affiliated with the IAAF or the International Amateur Athletic Federation which governs the sport worldwide. It is likewise the representative for track and field, race walking and the marathon to the United States Olympic Committee.

There are three levels of officials, Association, National and Master. Each has its own qualifications. You begin at the Association level after you have attended an officiating clinic and taken the association level test on the USATF rulebook. Each association sets the requirements for their local area. The Pacific Association covers all of Northern California from San Luis Obispo to the Oregon Border and east to beyond the Reno/Sparks area. If you want to join us or get further information in becoming a certified official, you can contact the author or the Officials Certification Chair, Jim Hume at 1561-B Marina Court, San Mateo, CA 94403 or E-mail at Jimhume.certchair@sbcglobal.net. If you are from another association, contact your local association to obtain their requirements. You can get their address from the USATF Website at www.USATF.org or www.usatfofficials.com under the certification chair. At the present time USATF is the only one who is training and certifying W&M officials for USATF, NCAA and high schools in northern California and northern Nevada.

PREMEET REQUIREMENTS:

EQUIPMENT:

This manual will describe equipment that has been developed by Norm Morrison and Carl Strombom based on their years of measuring implements in the Pacific Association. This is the equipment that is for rent from the Pacific Association and is used at the University of California, Berkeley and Stanford. You can make some of your own if you have access to shop facilities. In the future, the Equipment and Facilities Subcommittee of USATF plans to make standards for being able to checking the TRACKMASTER™ and other equipment being used for implement certification.

Measuring equipment must be handled with care and properly stored, maintained and calibrated in order to do the best job. The misuse of equipment is usually the biggest problem and is the result of lack of knowledge or training. Misuse leads to damage which results in inaccuracies even when a competent person is using it.

NOTE: All measurement equipment should be checked at least annually against a known standard. The standard should be traceable to a Bureau of Standards standard. This is true for scales, weights and measurement devices i.e. tapes and calipers. When you first get your equipment, make sure that all implements are measured, verified and marked correctly and you know the use for each. Each year check that the gauges have not been damaged enlarged or incurred weight loss as a result of usage.

DIFFERENCE IN EQUIPMENT:

The Pacific Association, the University of California and Stanford have double pan balances. When using a double pan balance the weights go on the left and implements on the right. This can be tested by moving the ounce slide to the 1 ounce and see which way the balance moves, i.e. it take one ounce of weight or pressure on the side which should have the implements to rebalance the scale to zero. Note some of the scales have a plus and minus designation to indicate over weight or underweight.

Remember every measurement has some level of error or uncertainty associated with it. For a scale that uncertainty is called tolerance. Every scale but even an electronic scale has a degree of uncertainty. However, because there is a digital read out people tend to believe all the significant places shown. Within the tolerance/accuracy of that scale you cannot tell if the scale is weighting lighter or heavier than the indicated weight by plus or minus that tolerance. Or put another way you cannot tell the difference between the following two implements one that weight exactly at the measured weight minus the tolerance and one that weighs the measured weight plus the tolerance. Thus a scale that can measure to plus or minus 1 gram in a kilogram



TABLE 4 THROWING IMPLEMENT SPECIFICATIONS SUMMARY MINI JAVELIN

cannot tell the difference between a 1 kg discus weighing 999 g and 1001g or 0.999 kg and 1.001 kg. Both could read 1.000 kg on the scale. Similarly if a discus showed 0.999 kg it could weight 1.000 kg or 0.998 kg. Thus you would have to accept as legal a discus that weighed 0.999 kg on this scale but not one that weighed 0.998 kg. This is statistical reality. Obviously if you have a more accurate scale with a lower tolerance then you might be able to distinguish between the disci. Remember that there is a tolerance for any scale but particularly the electronic scale. Because there is a read out people tend to believe all the numbers.

Weights: Unless you are using an electronic scale, you will need the following weights depending on the competition:

	Men's Open		Women's Open
Shot and Hammer	16 lb.		4 kg
Javelin:	800 g		600 g
Discus:	2 kg		1 kg
Weight	56, 35 lb. (we don't have these)		20 lb. (must use most lb weights and rider)
	Junior Men		Junior Women
Shot and Hammer:	6 kg.		4 kg
Javelin:	800 g		600 g
Discus:	1.75 kg		1 kg
	Collegiate Men		Collegiate Women
Shot and Hammer:	16 lb.		4 kg
Javelin:	800 g		600 g
Discus:	2 kg		1 kg
Weight:	35 lb.		-
	Men's Masters		Women's Masters
Hammer:	4, 5, 6 kg, 16 lb.		3, 4 kg
Shot:	4, 5, 6 kg, 16 lb.		3, 4 kg
	Men's Masters		Women's Masters
Javelin:	600, 800 g		400, 600 g
Discus:	1, 1.5, 2 kg		1 kg
Weight/Superweight:	12, 16, 20, 25, 35 lb.		12, 16, 20 lb.
	High School Boys		High School Girls
Shot:	12 lb.		4 kg
Javelin:	800 g		600 g
Discus:	1.6 kg		1 kg
	Youth Boys		Youth Girls
Shot:	6, 12 lb., 4 kg		6 lb., 4 kg
Javelin:	800 g		600 g
Discus:	1, 1.6 kg		1 kg
Athletics for the Disabled:			
Cerebral Palsy	Javelin 600 g 800 g	Discus 1, 1.5 kg	Shot 4, 6 lb., 3, 4, 5 kg
Wheelchair	600 g 800 g	1, 1.5kg	2, 3, 4, 5 kg 4, 6, 8 lb.
Blind	400, 600, 800 g	1, 1.5, 2.0 kg	3, 4, 5, 7.26 kg
Ambulatory	Javelin 600, 800 g	Discus 1, 1.5 kg	Shot 4, 5, 6.25 kg



TABLE 4 THROWING IMPLEMENT SPECIFICATIONS SUMMARY MINI JAVELIN

	Javelin	Discus	Shot
Special Olympics Hearing Impaired	800 g	2.0 kg	3, 4, 6 lb., 4 kg 7.26 kg

Weights should be handled with care so as not to damage them so they either gain weight, less likely or loose weight by being dropped.

Note: There are 16 oz in a lb., 453.5924 g per lb., 28.349527 g per oz, and 2.20462 lb. per kg.

WEIGHTS AND MEASURES TOOLS FROM THE PACIFIC ASSOCIATION:

The following makes up the W&M instruments for the association:

- Double Pan Balance Scale
- Box of Weights
- Tool Box of Instruments
- Hammer Stretcher
- Hammer Measuring Device
- Javelin Board (2 Pieces)

SCALE WEIGHTS:

The weight box has the following weights which can be used to measure most of these implements but not all (400g, 500g, 700g, 6 kg, and weights over 16 lb.). These weights are traceable to the NBS and should be handled carefully as not to damage them and loose some of their weight.

600 g and 800 g

which allows you to weigh most common javelins but not the 400 g, 500 g and 700 g javelins. The 400 g can be approximated by using the ounce slide at between 14 oz and 14 1/4 oz since you can't get smaller than 1/4 oz or 7 g. The correct value is 14.1 oz. This translates into 397.1 g to 404.2 g respectively. The accuracy for this is poor since it is about 1%. But you won't have more than one or two to weigh in usually. The 500 g can be approximated by the 1 lb weight plus 1.5 and 1.75 oz which is 496.1 g to 503.2g. The 700 g can be approximated very well by the 600 g weight plus 3.5 oz which is 699.2 g.

1 lb.

2 lb.

3-5 lb.

1 kg

2-2 kg

which allows you to weigh the discus at 1 kg, 2 kg, 1.5 kg (3 lb. and 5 ounces which is 1.05025 g or 2.5 g too much) and 1.6 kg (600g plus 1 kg), the shots/hammers at 6 lb., 3 kg, 4 kg, 5 kg, 12 lb., and 16 lb. The missing one is 6 kg since you can only get to 13 lb. and 3.5 or 3.75 oz, which are 5.996 and 6.003 kg or 4 grams off. At this weight that translates in 0.066% or 2 in 3000. For the 6.25 kg shot for wheelchairs you can use 13 lb. and 12.5 oz which translates into 6.251 kg or 1 g over. For these implements many of the electronic scales would be better.

Note: For conversion purposes there are 16 oz in a lb., 453.5924 g per lb., 28.349527 g per oz, and 2.20462 lb. per kg.

Scale Weights for Various Implement Weights

Implement Weight	Scale setting in oz.	600 g	800 g	1 lb.	2 lb.	5 lb.	1 kg	2 kg	Actual Weight
Number Available	16	1	1	1	1	3	1	2	
400 g	14-14.25								397.1-404.2 g



TABLE 4 THROWING IMPLEMENT SPECIFICATIONS SUMMARY MINI JAVELIN

500 g	1.5-1.75			1					496.1-503.2 g
600 g		1							
700 g	3.5	1							699.2 g
800 g			1						
Implement Weight	Scale setting in oz.	600 g	800 g	1 lb.	2 lb.	5 lb.	1 kg	2 kg	Actual Weight
1 kg							1		
1.5 kg	5			1	1				1.5025
1.6 kg		1					1		
2 kg								1	
6 lb.				1		1			
3 kg							1	1	
4 kg								2	
5 kg							1	2	
12 lb.					1	2			
6 kg	3.5-3.75			1	1	2			5.996-6.003
6.25 kg	12.5			1	1	2			6.251
7.26 kg/ 16 lb.				1		3			7.2575

The accepted conversions (although not exact) are:

lb.	kg	lb.	kg.	lb	kg
12	5.450	25	11.340	98	44.50
17	7.260	35	15.880	200	90.80
21	9.080	56	25.400	300	136.10

Note the metric weights are the legal weights, not the lb or imperial weights.

Note you can use coins to make up the small difference for the 16lb shot by adding a penny to the 16lbs.

Coin	Weight, kg
Dime	0.0020
Penny	0.0025
Nickel	0.0050
Quarter	0.0055

JAVELIN MEASURING GAUGE:



TABLE 4 THROWING IMPLEMENT SPECIFICATIONS SUMMARY MINI JAVELIN

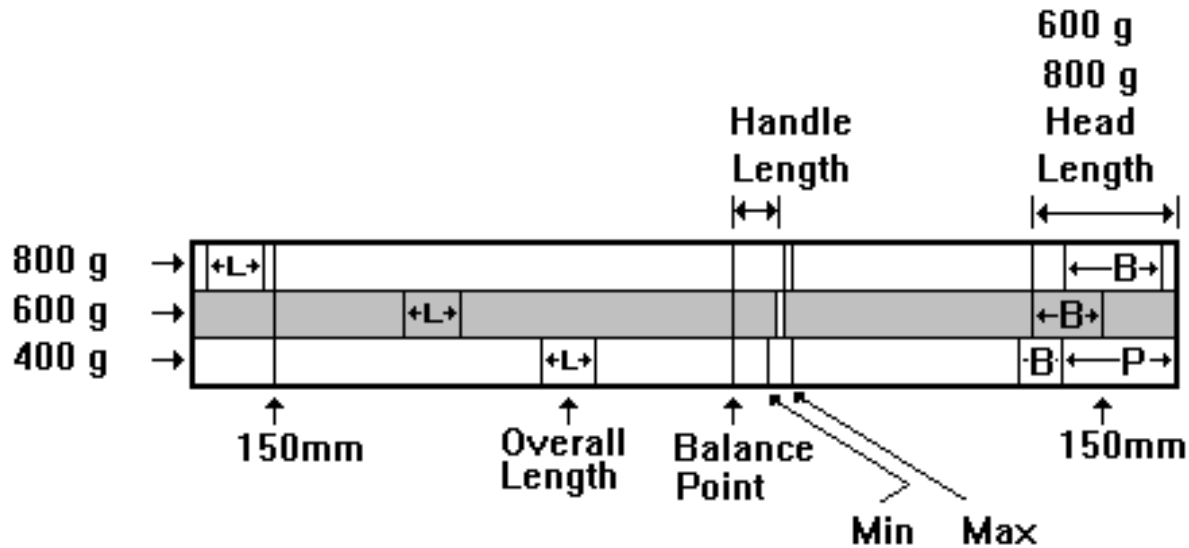

L=Overall Length
B=Balance Point
P=Point Length

JAVELIN BOARD

Not to Scale

You can make your own out of wood or even tape on the edge of the table. The following example was made in three pieces so it could be easily transported. It is color coded so that three javelin weights can be easily measured. In fact, it can also add the 500 g and 700 g javelins and the Youth Javelin. The dimensions are:

Overall Length: 9 ft-9 in / 3.0 m
Overall Width: 3 ½ in / 9 cm or 5 1/2 in for all five.
Each Piece: 3 ft 3 in / 1.00 m

It is made out of hardwood with pieces of shelf hanger pieces or aluminum angle as sides so the javelin doesn't roll off. All marks were engraved into the wood before it was painted for accuracy. The three boards are held together by hinges and pins to assure that the length is always the same. Alternatively, the javelin board could be laid out on a paper or cloth template that could be rolled up and then tapped to a table or the floor. Then you would only need to have a hinge or other sharp edge that you could place at the balance point.

PACIFIC ASSOCIATION TOOL BOX INDEX:

This box includes the various manuals, markers and measuring devices for all the implements.

Weights and Measures Signs: Paper signs to indicate location of Weights and Measures in a red folder.

Weights and Measures Spec Tables: Complete tables of specifications for all implements in an orange folder.

Weights and Measures Implement and Impoundment Forms: Copies of forms from Appendix.

Marking Pens: Some Marks a Lots pens are available in the kit for emergency use, but these aren't the best marking devices.

Implement Measuring Tape: 3 meter/10 ft combination tape for javelin and event circles. This can also be used for measuring the bar in the High Jump and Pole Vault.

Level: Used to level scale location and for javelin board to get balance point.



TABLE 4 THROWING IMPLEMENT SPECIFICATIONS SUMMARY MINI JAVELIN

Calculator: For use in calculating percentages for javelin measurements.

Caliper: Used to measure the hammer wire diameter and the various points on the javelin.

Newer kits have an electronic one. Extra battery in the box.

Rulebook: Copy of NCAA rulebook since it is the one most used.

Handbook: There is a copy of this handbook in a red folder. Note included in back are the implement specification tables for all implements in case the individual sheets get misplaced.

Straight Edge: at least 50 centimeters long as a fast check of the javelin taper or to measure the taper when used with feeler gauges as well as measuring the slope of the discus.

Angle Gauge: For checking javelin point.

Shot and Hammer Diameter Gauges: For 16 lb., 12 lb. and 4 kg. If doing a Masters meet, you will need to use the appropriate one. Variations in Masters Diameters means you will need to use more than one gauge on the shot.

Discus Gauge: Single one for 1 kg, 1.6 kg and 2 kg. By appropriate use of the gauge you can do all but the minimum diameter of 200 mm for the 1.5 kg master discus also. But since it is only 11 mm smaller than the maximum which is the same maximum diameter as the high school implement you can use a stop or insert 11 mm thick. If you're going to do a lot of Master's meets you may want to get a new Trackmaster gauge. See specification summary table in appendix)

Notebook: To do any needed calculations and to record calibration procedure. Also record the following information on any implement that is impounded. Owner/Athlete, School, type, brand, failing parameter, condition of implement, i.e. is failure due to wear or damage or is it a new implement. See Appendix for a sample Weights and Measures Inspector of Implements form.

OTHER MEASURING DEVICES:

Javelin Measuring Gauge: You can make your own out of wood or by marking a folding ruler or cloth tape. Either of the latter should be taped to the front side of one of the tables for easy gauging. The association's are made of wood and allow all of the length measurements as well as checking the balance point. An alternate which you can make is shown under personal equipment on page 4.

Hammer Stretcher and Measuring Gauge: The hammer stretching device is used to straighten the wire so an accurate measurement can be made. The gauge is used to do the measurement once the wire is reasonably straight and or taut. Don't put so much pressure on it that you bend the handle. Be careful in using it because the handle can come off the retainer.

GENERAL PROCEDURE FOR ALL IMPLEMENTS:

NOTE: When using any scale, treat it carefully. When removing implements or weights, make sure to do it gently so that you do not damage the knife edges or bearings. This is particularly true for a single pan balance such as that used in the TRACKMASTER™ or the double pan available in the Pacific Association kit. Hold the bar when removing weights or implements so the bar doesn't damage the knife edges or bearings or you don't move the counter balance calibration weight. With care, your scale will last a long time. Without this care you can damage it very quickly. Remember scales and weights need to be calibrated periodically. With normal use that should be at least bi-annually if not annually. When moving scales make sure to protect the knife edges or bearings by immobilizing the scale. You can use foam rubber under the arm and/or on top of it for protection. You should calibrate the scale before use each day or each time you move it. For the double pan try weighing two identical weights and then switching them to make sure you are balanced and level enough. For the Pacific Association equipment you can use either the 2 kg or the 5 lb. weights.

Before putting any weight on the Pacific Association scale, test the movement of the pan(s) to make sure it moves easily and isn't bound by anything. When putting an implement on the pan make sure it is well balanced. For hammers, shots and weights, you can use a washer on each pan (so balanced) to stop the implement from rolling. On an electronic scale with one pan you can tare the added weight out. For the hammer put the ball in the handle loop. Be careful because if you have a new wire, it may spring out. Make sure the wire isn't hitting anything while you are trying to weight the hammer. For the javelin, the center of



TABLE 4 THROWING IMPLEMENT SPECIFICATIONS SUMMARY MINI JAVELIN

gravity is near the front of the handle so tend to place the javelin so that the front of the handle is near the center of the pan. In general you should place the weights and the implements as near to the center of the pan as possible (see also discussion of tolerance/accuracy under the equipment section on scales).

The following sections detail how to certify each of the implements. Because there are subtle differences between the wording in each rulebook, it is always a good idea to review the appropriate rulebook the night before the meet particularly if it is for a meet that is using a different set of rules than you have recently be using. Always use the rulebook as the ultimate authority, unless you know there has been in intervening change. The E&FS committee tries to keep you apprised of these changes as they occur during the year. If you have e-mail, send your address to georgeklee@aol.com so that this can be done in a more timely fashion. These sections try to point out the similarities and the differences between the books.

SHOT: (Numbers refer to section in National Manual)

3. Weigh the shot. Note if you are using the Pacific Association double pan scale place an equal size washer on each pan to keep the shot from rolling off the pan, and place the weight on one pan and the shot on the washer on the other one.

DISCUS:

3. In measuring the thickness of the discus be sure that the measuring tool is perpendicular to the sides. Some thickness measuring devices are too thin so that if not held properly might indicate a correct thickness when it really was too thin. This gauge should be at least a ¼" thick to minimize this problem since at this thickness it is hard to use the gauge and not be perpendicular to the sides. Note there are both a maximum and a minimum. The Pacific Association equipment does not have the maximum 13 mm gauge.

HAMMER:

2. When you use the hammer wire stretcher make sure the wire is straight but not stretched and not curled. Be careful not to apply too much tension so that you start to stretch the wire, the wire loops, or bend the handle. The weight of the hammer itself is usually not be enough to straighten the wire, particularly if the wire has been curled from normal use or for transport. You may need to apply some additional tension to these hammers. In using the hammer stretcher, be careful to make sure the handle and ball are properly placed so that they won't come loose as you increase tension. Tighten until the wire it is reasonably taut. Don't bend the handle. When taut use the gauge to check the maximum and minimum lengths and the wire diameter particularly at each end. Be careful in doing this measurement. If you are using the TRACKMASTER[™] hammer stand, we recommend you use a "C" clamp to hold it firmly to the table surface.

5. We don't have this check in our kits although it can be simply made. Check the center of gravity by placing on 12 cm sharp edge orifice. It passes if it doesn't fall off.

WEIGHT:

2. Check the weight. Typically our scales will not weight this implement (too heavy) so you will need to make alternate plans for weighting it.

JAVELIN:

3. Use the javelin board to measure the overall length and the incremental distances as shown in the equipment section, page 4. Alternately you can mark a retractable steel tape or adhesive tape on the edge of a table with the necessary dimensions. This allows you to quickly lay the javelin on it and check the overall length, the length of the point, and length of the grip. You can also mark the 150 mm tip and tail marks used later for contour measurements. Note the 400g measurements are done at 125 mm.

5. Check the weight. If you are using the Pacific Associations weights, we don't have a 400g, 500g or 700g weight but you can use the sliding scale to get close. See previous table for values needed.



TABLE 4 THROWING IMPLEMENT SPECIFICATIONS SUMMARY MINI JAVELIN

6. Check the tip to see if it meets the maximum of forty degree taper using the tip guide. This can also be done with a plastic protractor and several pieces of tape. The Pacific Association kits have a measuring device. Since the spec is a maximum it needs to hit the side at the bottom or not hit the sides at all to be legal.

USE OF OTHER METHODS:

If you know of other methods that should be discussed please pass them along to the editor at 5104 Alhambra Valley Road, Martinez, Ca. 94553-9775, 510-229-2927 or e-mail georgeklee@aol.com.