

VERTICAL JUMPS©

HIGH JUMP

POLE VAULT



By George Kleeman

2007

PRICE \$5.00

This monograph is part of the copyrighted USATF National Officials Monograph Series on how to officiate track and field. Each monograph covers the various techniques for each officiating assignment. These monographs are intended for more in depth understanding of each job. They are intended for both the novice and seasoned official. They cover the real details of the job and how it should be performed. They summarize various techniques to accomplish the job. These monographs belong to the author and the USATF National Track & Field Officials Committee. They can be copied and used for officials training only.

INDEX

Title	Page
Index	i
Vertical Jump Officials	1
Vertical Jump Rules	1
Introduction	1
Safety	2
Call up/Timing	2
Warm-up Times	4
Rotating Flights	4
Absences	4
Aids	5
Shoe Restrictions	5
Coaching	6
Use of Flags	6
Fouls	6
Disqualification	8
Ties/Places	8
Standards/Crossbars	8
Officials Needed	10
Measurement	11
Summary of High Jump Rules and Guidelines	12
Summary of Pole Vault Rules and Guidelines	13
Equipment Specifications	14
Step by Step Guide for VJ Officials	16
Before Competition	16
Location of Plane of High Jump Bar	17
Location of Plane of Pole Vault Bar	17
Warm-Up Time	17
Instructions	18
Competition	20
Recording	21
Measuring	22
Three or Fewer Jumpers Remaining in Competition	22
After Competition	22
Applicable Major Rule References	22
High Jump Layout	24
High Jump Equipment Check Lists	25
Pole Vault Layout	26
Pole Vault Equipment Check Lists	27
High Jump Officiating Positions	28
Combined Pole Vault & High Jump Assignment Sheet	29
Pole Vault Officiating Positions	30
Guideline for Pre Competition Activities	31

The credit for pictures goes to Lawrie Robertson.

VERTICAL JUMP OFFICIATING CLINIC

VERTICAL JUMP OFFICIALS

Field event competitors combine the talents of speed, strength and control. The central role of field event officials is to focus on detail and maintain consistency. They must be attentive to watch for correct form, approved equipment, time constraints, accurate and consistent measurement and a fair competitive opportunity for every competitor. That means that each competitor competes with an equal advantage in relation to the equipment used and the competition conditions. Most importantly, each field event official must give his or her full attention to maintaining safety at his or her competition site. Vertical jump officials share some exceptions to the general field event rules, like the initial height of the bar and the increment for raises is predetermined. The measurement of the bar height is perpendicular to the ground and record attempts are measured before they are attempted. A jumper may enter the competition when they want and take only the attempts they chose. Three consecutive failures to clear a height disqualifies the athlete from further competition except in the case of a tie for first place.

VERTICAL JUMP RULES

INTRODUCTION:

Let's start first with some definitions.

A **trial** is an attempt in a field event.

A **qualifying competition** is a separate competition in which contestants qualify for the competition proper by either making the qualifying to make the competition proper. This procedure is normally only used in championship meets and usually only in USATF and IAAF meets. If an athlete makes the qualifying mark he is insured of entry in the competition proper and so is not eligible to continue in the qualifying competition. Qualifying marks do not carry forward into the competition proper.

Although other field events have flights and preliminary rounds, neither is used in vertical jump competitions.



High Jump Clearance



Vault to Bar



Over Bar

The vertical jumps encompass the events of high jump and pole vault. Many of the same rules apply to both so they are often combined as an area of officiating expertise. However, in practice usually you end up having to choose one or the other because of time constraints. Both can be rather long events since the number of attempts depends as much on the quantity and quality of the field and the starting height as anything else. The variations in the rules between the governing bodies are greater for the vertical jumps than any other event. Generally a good jumper will take between 7 and 10 attempts during the competition although the younger athletes sometimes take as many as 15 or more.

The fact that field events generally require athletes to combine the talents of speed, strength and control is particularly true of the vertical jumps which require the speed of a sprinter, strength of a hurdler and control beyond most other events. Because of the time factor, the vertical jumps have priority over other field events

just as running events have priority over field events. However, a round is completed when everyone has made, passed or failed at a height. Competition in the vertical jumps should not be held up by the absence of an athlete as described below.

SAFETY:

Always be attentive when you are around the jumping areas particularly for other field or track events, which might impact yours. Field events can be dangerous if you are hit with any of the implements or get in the way of a jumper. Do not cross runways or run-up areas during a competition. Always keep your eye on the runway. If possible have run-up areas flagged off. Be prepared for the unexpected. Pay particular attention during the warm-up period since the time between jumps is much shorter and your attention may be diverted with the multiple activities occurring. For the most part try to keep warm-ups in a safe area, usually on the runway or apron. Do not let another jumper start until the last jumper has cleared the pit. Continuously monitor the pads to make sure they aren't moving. Readjust them as needed. Make sure the area is clear of items that might cause injury. Monitor the zero point line and the marking on the pad to insure they align. In high school there are requirements for a padded collar surrounding the plant box and restrictions on the type and weight classifications for poles. It is the athlete's and the coach's responsibility. An athlete can only use a competition label pole rated for his or her weight during competition. Training poles, which have a wider weight range, are not allowed. The event judge must approve the use of a pole of another competitor and verify if its weight is appropriate. Unless the Referee considers the take-off or landing pit has become unsuitable, the uprights in the high jump shall not be moved during the competition. In such a case, the change shall be made only after a round has been completed if at all possible.

Stop any event where safety might be compromised whether it is your event or another.

It is never safe to allow the pole vault standards to be placed in front of zero even if allowed by the rules. This is because the apex of the jump will be in front of the pad and pole plant point, increasing the chances of the jumper, particularly a beginning jumper, coming down in front of the pad and thereby being injured. In fact youth and high school meets the standards should not be set closer than 40 cm or 16" back from zero and the NCAA has restricted the standards to not closer than 45 cm or 18" from zero.

CALL UP/TIMING:

NOTE: This is a complicated section with each rulebook having exceptions. Consequently it is advisable to read the applicable sections of the applicable rulebook before each competition to make sure you are applying the proper rules for that competition.

The Head Event Judge or recorder calls the competitor up to begin his or her trial. This is normally done by saying, ---- is up (about to compete), ----- is on deck (next to compete) and ---- is on hold (second in line to compete). The time allowed for a vertical jump trial to start for all but High School pole vault is now 1 minute from the time the athlete is called up. The High School pole vault is 1 1/2 minutes. There is no time foul as long as the attempt is started before the time has elapsed. This is open to some interpretation. But if a jumper always does the same motions before starting his run up, namely moves his arms back and forth three times while visualizing his jump, then you should consider him to have started his run up even though he hasn't taken the first step. With or without a clock an official should indicate to the athlete when there is 15 (USA & IAAF) or 30 seconds (NCAA) remaining by raising a yellow flag and/or calling out 15 or 30 seconds. The flag in IAAF and USATF competitions must be held up until the jump is completed or the time has elapsed. It is a matter for the Referee to decide, having all the pertinent information, what is an unreasonable delay but the normal guideline should not be exceeded. In high school events, there is no consideration for more than the normal increment between consecutive trials by the same athlete. In USATF, NCAA and IAAF events, the increment is increased to 2 minutes for high jump and 3 minutes for the pole vault.

Once the time has started the competitor cannot pass without being charged with a trial. A competitor must pass an attempt before being called up. If the competitor passes after being called up then the competitor will receive a time foul. The subsequent jumper may wait until the time for the passing jumper has ended before being called up if he or she so desires. The fact that the athlete gets a foul because of when the pass was announced is important because ties are more common in vertical jumps and because of the way ties are broken.

The following table summarizes the different time limits for vertical jumps. With the recent changes in all of the rules, there are even more differences. When the number of competitors remaining in the competition is down to 2 or 3 competitors, then the time increment between jumps increases. When only one competitor remains it increases again. Note these increases occur at the start of the next height. This rule does not apply at the end of a round of jumps. However, if there is only one or two jumper at the end of a round, then the consecutive jump rule may apply. This is true in open as well as combined event competitions.

Time in Minutes for Trials

	-- OPEN --		MULTI-EVENTS ¹⁾	
	HJ	PV	HJ	PV
Greater than 3				
USATF/IAAF	1	1	1	1
NCAA	1	1	1	1
HS	1	1 1/2	1	1 1/2
If 2-3 remaining ²⁾				
USATF/IAAF	1 1/2	2	1 1/2	2
NCAA	2	3	1 ¹⁾	1 ¹⁾
HS	3	4	3	4
If 1 remaining				
USATF/IAAF	3	5	3 ⁴⁾	5 ⁴⁾
NCAA	2 ⁴⁾	3 ⁴⁾	2 ⁴⁾	3 ⁴⁾
HS	5	6	5	6
CONSECUTIVE ATTEMPTS				
USATF/IAAF	2	3	2	3
NCAA	2	3	2	3
HS ⁵⁾	-	-	-	-
	HJ	PV	HJ	PV
WARNING				
USATF/IAAF	1/4	1/4	1/4	1/4
NCAA	1/2	1/2	1/2	1/2
HS ⁵⁾	-	-	-	-

Table Footnotes:

- 1) Note difference in rules.
- 2) Note to be fair to all competitors this change occurs when a new round is started with only 2 or 3 remaining then all should be given the extended time for each jump including their first jump.
- 3) There is no rule covering this item but with only one remaining apply the consecutive jump rule when applicable.
- 4) Same as consecutive attempts after the first attempt which will have the normal time limit unless a consecutive attempt. (Note this normally applies only to vertical jump competitions since other events should not have more than one attempt per round.)
- 5) There is no rule covering this item.

The competitor should not be called up until the crossbar is in place, the pit is adjusted and/or the standards are set at the predetermined values for each individual jumper. Changes in settings should be communicated before the standards are set; otherwise any resetting will be done as part of the timed trial period.

Normally the vertical jumps are run in a single continuous flight, in the order drawn by lot. But when there are a lot of competitors the high school rulebook does allow for flights. However, the more common procedure is to

have a continuous but rotating flight of three to five jumpers in what is called "Three or Five Alive". This procedure is allowable in high school and NCAA competitions. USATF allows rotating flights until the field is reduced to less than 13 competitors if there isn't time to have a qualifying competition. Otherwise both the IAAF and USATF rules call for one continuous flight. In a NCAA meet when the field is fewer than nine then you change to a continuous flight. The change from a rotating flight to a continuous flight should be made at the next height change.

WARM-UP TIMES:

Division	Time/ Jumps	When	Enter
High School	1 Jump at height change w/o bar	3 Consecutive Heights Passes	Must Enter
Youth	1 jump at height change w/o bar as earned	3 Consecutive Heights Passes	No
Masters	1 jump at height change w/o bar as earned	3 Consecutive Heights Passes	No
Open	None		
IAAF	None		
NCAA	1.5 min HJ, 2 min PV at height change w/o bar	One hour since last jump	No

ROTATING FLIGHTS:

In "Five Alive", the first five jumpers open the competition and then as each passes the height, clears the bar or is eliminated then the next competitor in order will be moved up so that the number of competitors remains constant. For example, if competitors a, b, c, d, e, f, g, h and i start the competition, then in a "5 Alive" sequence then jumpers a, b, c, d, e would start the first round. If c was to pass or make the height then I add jumper f after jumper e jumps followed by the second jumps for a, b, d, e and f. If b and d make the height then I would add g and h at the end so the next jumpers would be g and h (first jumps), then a, e and f (third jumps) would jump followed by g and h (second jumps) and finally i (first jump). The next round would be g and h for their third jumps and i for the second jump if needed. There are alternate ways to do this, like adding the new jumper in place of the vacated jumper. But with "Five Alive" I find this too difficult to keep the order clear, since you are jumping all over the recording sheet. It is, of course, a little easier if there are less in the rotation. The other alternate is not to add the new jumper until the following round. The first round as above would be a, b, c, d, e followed by round two of a, b, d, e, f with the third round being a, e, f, g and h. The fourth round would be f, g, h and i followed by g, h and i if none made it in the fourth round. Sometimes it makes sense to add a sixth athlete at the end of a round so there won't be just one left to jump alone.

ABSENCES:

This is being repeated here since misses are so important in vertical jumps. An athlete must obtain permission to compete in some other event, which will require missing his normal turn in the rotation. It is possible for the athlete to take his jump out of turn as long as the bar height is not changed. They could have three attempts in a row but that is not recommended. The bar should be raised to the next height without delayed when all but the absent athlete has passed, fouled or made the current height. In IAAF and USA Track & Field sanctioned events athletes who have been excused and subsequently are not present for that trial shall be deemed to have passed that trial once the period allowed for the trial has elapsed. This is of primary importance in the vertical jumps only. Remember it is a matter for the Referee to decide having all the pertinent information what is an unreasonable delay. The exception is in USATF Youth meets. The Games committee or the affected event judge (if delegated) will set a time limit for return for an athlete excused from a high jump or pole vault for a running event. Failure to return within these limits shall result in forfeiture of missed attempts. As the head of the event you should attempt to understand where and how long an athlete expects to be gone so you can effectively run your event. Write down the time the athlete leaves and returns. Have him report in and out to the head of the event. You must balance the needs of the excused athlete with those of the other competitors. Remember the guiding principle is a fair competition for all without an advantage or disadvantage to any. Make the best accommodation you can, knowing all the circumstances. In big meets a stricter interpretation is mandatory to keep the events on time. In international meets and some major national meets, the athlete will have to be accompanied by an official if he leaves the venue unless the athlete is going to another event. The following is a summary of items which are to be considered in high school meets when trying to determine what should be the time allowed to compete in another event. These are also appropriate for consideration in other competitions.

1. The athlete must receive permission to leave from the event judge.

2. The event judge may allow the competitor to take a trial out of order before he leaves.
3. The judge should take into account the length of the race or event for which the competitor is being excused.
4. Record the time excused.
5. In the vertical jumps, if the competitor doesn't return by the time the bar is due to go up, the judge will pass the competitor to the next height.
6. Coaches must take into account the limited time allowed to compete in another event when determining the events any individual athlete is entered.
7. The event judge needs to be fair to all competitors, not only the athlete with more than one event.
8. Record the time the excused athlete returns and checks in.

In USATF and IAAF meets, if an excused athlete doesn't return by the time the bar is to be moved then once the time for the jump has elapsed the athlete should be deemed to have passed the height.

Several of these items are appropriate for consideration in other competitions also.

AIDS:

As an aid in the vertical jumps a windsock should be placed near the takeoff point to enable the competitors to determine the approximate direction and strength of the wind.

Generally taping of hands or fingers in pole vault is not allowed unless there is an open wound. The taping of the wrist is acceptable. The use of gloves is only allowed in the NCAA pole vault. The wearing of a weight or lifting type belt is OK. There is no longer any restriction on the wearing of watches. However, jewelry other than watches and religious medals which must be taped to the chest, is not allowed in high school events.

All governing bodies allow the taping of the pole vault pole with two layers of tape and use of a substance on your hands and the pole to improve your grip. However, the tape should not provide a handhold. The use of forearm protectors, taping of wrists and/or headgear protection is acceptable. The use of multiple layers of tape on the bottom of the pole to protect it from splitting is acceptable.

No flags or markers should be placed in the pit or impact area since they could interfere with safety. In both vertical jumps either one or two markers may be used. In the pole vault they must be placed alongside but not on the runway. In the high jump they can be placed anywhere except in the NCAA which restricts the location as not being closer than 2 meter from the standards. Likewise in high school competitions the Games Committee can set the limit and locations in the high jump. Warm up jumps are allowed without the bar as follows:

High School: One warm-up jump at the height change when entering the competition if the athlete has passed three consecutive heights.

NCAA: Warm-up time of 90 seconds for high jump and two minutes for pole vault is allowed between height changes if one hour has elapsed since the jumper's last jump.

Youth and Master: One warm-up jump taken at time earned, if the athlete has passed three consecutive heights. They cannot be saved. They do not have to enter the competition at that point.

Poles may have two uniform layers of adhesive tape at the top to help with holding on to the pole. The layers should not serve as a hand-hold, however. At the bottom it can also be wrapped to protect the bottom from damage or splitting. There is no limit to the amount of this tape. If for some reason a pole in high school competition does not have the weight limit, you usually can find the date of manufacture, the weight, flexibility index and other manufacturing information engraved at the top of the pole. If it isn't there, look near the pole tip. The high school rules require a 3/4" band in a contrasting color which has the maximum weight pole rating above or with in the top handhold position. There also should be a 1" band that indicates the top hand-hold position which is determined by the manufacturer.

SHOE RESTRICTIONS. The maximum height allowed for sole in the high jump NCAA, USATF and IAAF is 13 mm and the maximum heel thickness for the high jump in IAAF and USATF is 19 mm. In other field events shoes may be of any thickness in IAAF and USATF but are limited to the same 13 mm in NCAA meets. High school rules just limit shoes to those that don't give an unfair advantage. The head judge will normally make the ruling on the legality of shoes but it may be appealed to the referee.

COACHING:

Coaching on the field in an event area is generally not allowed. The exception is in the NCAA for meets with five or less teams. Teammates in NCAA meets can always help one another if they are in the event. In contrast in the USA Track & Field and IAAF advice by anyone within the competition area is prohibited. Athletes should be warned for the offense the first time. However, because of the number of incidents that have occurred in the pole vault all of the rulebooks now allow a coaching box to be set up near the competition and even on the field. But coaching or communication using non-technical devices is all right as long as it does not occur within the event area. Athletes leaving the competition area during the event for any reason may need to be accompanied. This means an athlete can get hand signs or go over to the edge of the event area to talk to a coach, who is not in the event area; i.e., stands nearby and the athlete doesn't leave the event area. A field athlete should not leave the infield or a throwing or jumping area to go over to the stands to talk to a coach. In High School and USA Track & Field Youth meets, the no coaching rule is still in effect. Although the High School rules have left it up to the Games Committee to define the restricted areas where only competitors and meet officials are allowed, implying coaching from an unrestricted area is all right (Rules 3.2.3.q and 4.5.9). The use of video replays, and communication via a wireless (cell phone, e-mail) or any technical device is prohibited. Use of cassette recorders, TVs, radios, and CD's, during the competition for an individual event is strictly forbidden in USATF and IAAF meets and may be done by the Games Committees for safety or noise reasons. This includes race walking on the roads.

USE OF FLAGS:

There are three flags normally used at a field event, white for a fair jump, red for a foul and yellow to indicate 15 seconds remaining on the time clock in IAAF and USA T&F and 30 seconds in NCAA. Flags are used in preference to verbal commands. However, for most events it is best to announce time remaining because often athletes are not facing the clock, if one is present. In fact, try not to yell fair or foul. If you must use something say "Mark" or "No Mark" although these are only required in high school meets. Flags are also used to communicate with the other officials at parts of the venue since often they can't hear comments at pit area. Once a competitor has completed an attempt, the head judge will indicate a legal attempt by raising the white flag straight over his head so everyone can see it or an illegal attempt by raising the red flag. Do not wave it around and hold it up long enough so the other field official can see it and acknowledge it. Do not yell "30 seconds" or raise your yellow flag overhead if an athlete has started the attempt. Wait until the athlete has completed the attempt. The jump is complete once the athlete has landed in the pit, assuming the bar was not hit in all but high school competitions. In high school the athlete must also leave the pit since there is the possibility of them knocking the bar down when exiting. Use the red flag or a cone on the runway to indicate that the pit is not ready for the next attempt and the white flag or remove the cone to indicate that the pit and standards are ready for the flight coordinator to call up the next jumper and start the clock.



Fair Attempt



Foul Attempt



Time Warning (Flag overhead)



Pit Not Ready

FOULS:

It is a foul if the athlete:

Applies to all vertical jump competitions:

- a. Is over the allotted time.
- b. Breaks the plane formed by the standards and the edge of crossbar near the take off point in the high jump and or the plane extended or the plane projected up from the pole vault box and touching the ground or landing area beyond the plane with any part of the body or with the pole without first clearing

the bar. There is a Masters exemption to this rule; namely a master competitor can touch the landing pad as long as no advantage is gained.

- c. Dislodges the crossbar with pole or body.
- d. Does not indicating intention to pass before being called up. Passing while on deck, on hold or before is acceptable.
- e. Uses of weights or grips of any kind.
- f. Steadies the crossbar.
- g. Violates the warm-up restrictions after competition begins; i.e., use of runways, apron or pit for practice unless they have been called up or have the permission of the head judge.

Apply to both vertical jumps but to only certain types of competitions.

- h. In a High School event stumbles into the standards and displaces the crossbar, even if the bar has been successfully cleared. This is not true in IAAF, NCAA or USATF.
- i. In a NCAA event hits the crossbar displacing it and also causes an improperly fastened support to slip. If the bar is not displaced then the head judge will rule no jump and allow another trial. In the NCAA, USATF or IAAF if a force other than the jumper displaces the crossbar before the jumper is over, the competitor shall be given another trial.

Apply to high jump only:

- j. Does not jump from one foot.

Apply to pole vault only:

- k. After leaving the ground moves the lower hand above the higher one or slides the upper one higher.
- l. In a High School competition leaves the ground in an attempt to vault and fails to clear the bar. In NCAA, USA and IAAF competitions, it is not a foul to leave the ground if the attempt is not otherwise a foul but the time will continue to run.
- m. Let his or her pole knock down the crossbar. No one shall be allowed to touch the vaulting pole unless it is falling away from the crossbar or uprights. If it is touched, however, and the head of the event (USATF and Referee for IAAF) is of the opinion that, but for the intervention, the bar would have been knocked off, the vault shall be regarded as a failure. In high winds the NCAA will allow the pole to be caught if in the opinion of the head official, the pole might blow into the bar or standards even if it were properly released.
- n. In High School competition uses a pole rated for less than the athlete's weight either during warm-ups or the competition. In fact if the pole is improperly marked or too light, the athlete will be disqualified.
- o. In High School events puts the upper hand above the top hand hold band.
- p. Puts tape on fingers or hands unless to cover an open cut. Taping the wrists or use of a forearm guard is OK. Gloves may not be used in the pole vault except in a NCAA meet. The first action here would be a warning and if the athlete refused to remove the tape then it could be declared a foul or the referee could disqualify the athlete.



Bar Coming Off



This is legal and not Volzing.



Foul if pole touched beyond plane.

It is not a foul if:

- a. During an attempt the pole breaks. The athlete should be awarded another attempt.
- b. The pole passes underneath the bar as long as it doesn't touch the bar.

DISQUALIFICATION:

Remember only a referee is empowered to disqualify someone from a competition. Others only make recommendations to the referee.

TIES/PLACES:

In vertical jumps since there are no preliminaries and finals, ties only occur at the end of the event. The one exception is in the case of a tie for the last qualifying position in a qualifying competition in an IAAF or USATF meet. In that case you take all true ties to the competition proper. That means you must apply the tie-breaking rules, without the jump off provision, to determine who is tied. Normally you do not have qualifying competitions in NCAA or high school meets. But if you did, the Games Committee would set the requirements.

In the more common case of a tie at the end of the event, it is broken first by the least number of misses at the tying height and if the competitors are still tied then by the total number of missed in the event. Where they occur is not important, it is just the total number of misses. Passes don't count. Number of total jumps doesn't matter. If there is still a tie and it is not for first place then those tied are awarded the same place. But if it is for first place then the tying competitors would get additional jumps until the tie for first place is broken. The jump off is sudden death in that if you miss you are out unless all jumpers miss. In practice the procedure is to give the tying competitors another attempt at the lowest height above the tying height that was attempted by any of those tying and resulted in their elimination. If the tie still remains after that jump then the bar will be lowered or raised by the amount shown in the table below for each governing body. The bar is raised by the increment if the height is cleared by two or more jumpers, or lowered if all jumpers miss at the height until the tie is broken. There is no passing in a jump off. If there is a qualifying position for another meet then ties for a lower position may need to be broken. To give the athletes the best chance, I recommend that those tying for that position be given a fourth attempt at the height that they went out at while they are warm. If the tie is broken fine, if not then have them come back at the end of the competition to break the tie. Do not have more than one jump during the competition to break the ties so that you don't delay the remainder of the competition.

Tie Breaking Increments

Rulebook	High Jump	Pole Vault
USATF/IAAF	2 cm	5 cm
High School	1 in	3 in
NCAA	2 cm	5 cm

Each competitor will be credited with the best of all his jumps including jumps which are part of a tie breaking competition. The following example shows a competition that ended with several ties and the resulting jump off.

COMPETITION	TOTAL JUMP OFF MISSES											PLACE	HEIGHT	
	1.75M	1.80M	1.83M	1.86M	1.88M	1.90M	1.88M	1.86M	1.84M	1.86M	1.88M			
A	O	O	XO	XO	XXX		2	X	X	O	O	X	2	1.86
B	P	O	XO	XO	P	XXX	2	X	X	O	O	O	1	1.88
C	XO	O	XO	XO	XXX		3						3	1.86
D	P	XO	XO	XO	P	XXX	3						3	1.86
E	XXO	O	XXO	P	XXX		4						5	1.83

Where X = FAIL O = CLEARED P = PASS

STANDARDS/CROSSBARS:

The starting height for the crossbar and successive increment are normally set by the Games Committee and should be announced to the jumpers before the start of the competition, preferably at the start of the warm up period. Under USA Track & Field and IAAF jurisdictions the bar must go up at least 2 cm at a time in the high

jump and at least 5 cm in the pole vault unless there is only a single competitor remaining. The increment should never be increased over the starting increment, it can decrease.

Typical increments used are

Rulebook	High Jump	Pole Vault
Youth(Req.)	5 cm	15 cm
USATF/IAAF(min.)	2 cm	5 cm
USATF/IAAF (Multi/Req.)	3 cm	10 cm
High School	2 in	6 in
NCAA	5 cm	15 cm
NCAA (Multi/Req.)	3 cm	10 cm

The minimum value must be used until there is only one competitor and for multievents, only the increment shown can be used throughout the competition.

Standards in the high jump should not be moved once the competition begins and so their location should be marked so they can be replaced if moved. If they must be moved because of damage to the jumping surface, it should be done only after a round has been completed. There should be at least 10 mm (0.4 in) between the end of the crossbar and the uprights. In the high jump the crossbar holders face each other. The standards should be at least 2 or more centimeters from the pit. There should be a 5 cm tape foul line indicator from three meters outside of one standard to three meter beyond the other standard. The front edge should be aligned with the front edge of the portion of the standard that holds the bar (see drawing on page 14).

Standards in the pole vault are moved for each competitor and normally move back as the height goes up since the apex of the jump has to move back as the pole gets longer and the vault higher. The pegs in the pole vault face the pit. The following table indicates the movement allowed under the various governing bodies. Note that the zero mark is considered to be at the vertical plane of the end of the pole planting box. There should be a 1 cm line through the back of the box extending to beyond the standards on either side. The front edge of the line should coincide with the zero point for the standards, i.e. the back of the standards where the pegs terminate (see diagram page 14). The plus dimension is in the direction of the pit, i.e. past the vertical plane while the minus dimension is in the direction of the runway and therefore, before the vertical plane. It helps if when the pit is out of the way a line is extended from the back of the box out to where the standards are set. For USATF and IAAF the bar must have only one flat side so that it is put up the same way each time.

HIGH SCHOOL	+40 CM TO + 80 CM	USATF	0 CM TO + 80 CM
NCAA	+45 CM TO + 80 CM	IAAF	0 CM TO + 80 CM
USA Youth	+40 CM TO + 80 CM		

NOTE: 45 cm is 18 inches and 80 cm is 31 1/2 inches and. 12 inches is approximately 30 cm and 30 inches is 76 cm.

Some feel it is never safe to allow the pole vault standards to be placed in front of the zero even if allowed by the rules. Note the pad behind the box should be between 10 and 15 cm back to allow for the bend of the pole in an open or NCAA meet. Having it back further leaves too much room for possible injury. In high school you need to have a collar to cover any exposed areas around the box.

The pegs for holding the pole vault bar are 55 mm long for all but a high school meet where the pegs can be 75 mm.

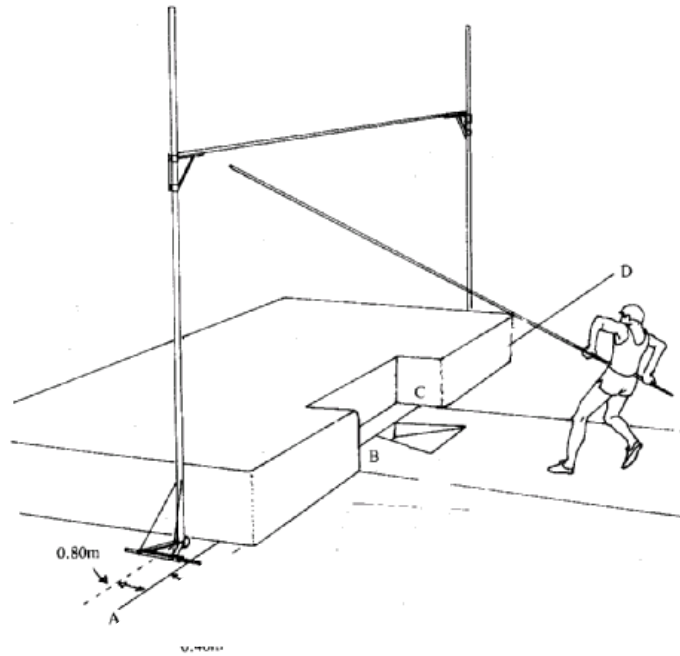

OFFICIALS NEEDED:

The activities for the pole vault officials include observing the takeoff area, rule on all trials, measure the height, determine contact with the crossbar, observe hands, enforce the time limit, control the runway, catch the pole, retrieve and replace crossbar, move standards and straighten pit, and monitoring the relative position of the zero point and the pit.

POLE VAULT	MINIMUM	NORMAL	MAJOR MEET
HEAD	1/3	1	1
RECORDER	1/3	1/2	1/2
STANDARDS/SET/FOULS	1	1	1
SET THE BAR	1	1	1
POLE CATCHER	1/3	1	1
RUNWAY CONTROL/TIMER	-	1	1
TAKEOFF OBSERVER	-	1/2	1/2
TOTAL	3	6	6

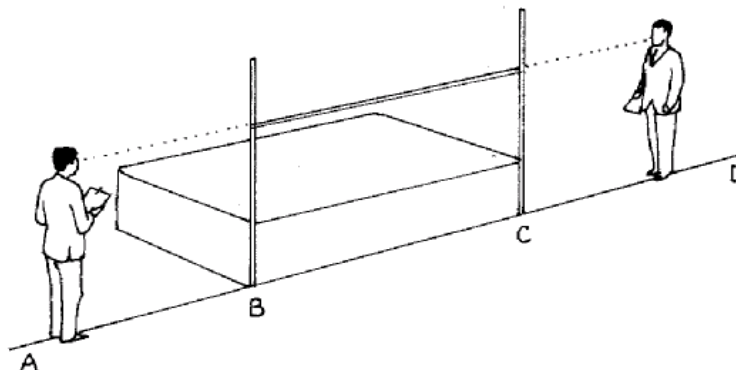

The activities in the high jump are for the two judges at the bar to rule on all trials, determine contact with the bar, measure the height and replace the bar and straighten the pit. The runway judge acts as marshal and keeps the time. The recorder keeps track of the jumps and calls up the competitors.

HIGH JUMP	MINIMUM	NORMAL	MAJOR MEET
HEAD	1/3	1/2	1
RECORDER	1/3	1	1

BAR/FOULS	1/2	1	1
SET THE BAR	1/2	1	1
RUNWAY CONTROL/TIMER	1/3	1/2	1
TOTAL	2	4	5



Location of High Jump Officials at Pit



Location of Pole Vault Officials at Pit

MEASUREMENT:

Measurement of the height of the crossbar should be made with a fiberglass or steel tape or bar graduated in centimeters. The measurement is made perpendicular from the ground or runway to the lowest point of the upper side of the bar. Note this is usually the center but it need not be. You need to determine the low point of whichever side you will be using for the upper surface before the start of the competition. This can be done by either taking several measurements along the length of the bar or sighting down it to find the location of the low point. Measurements should be made whenever the bar is moved to a new height. The measurement of the pole vault must occur when the standards are at zero to insure that the pole is perpendicular. Note the zero point is when front edge of the bar is perpendicular to the back of the inside edge of the vault box. Where that

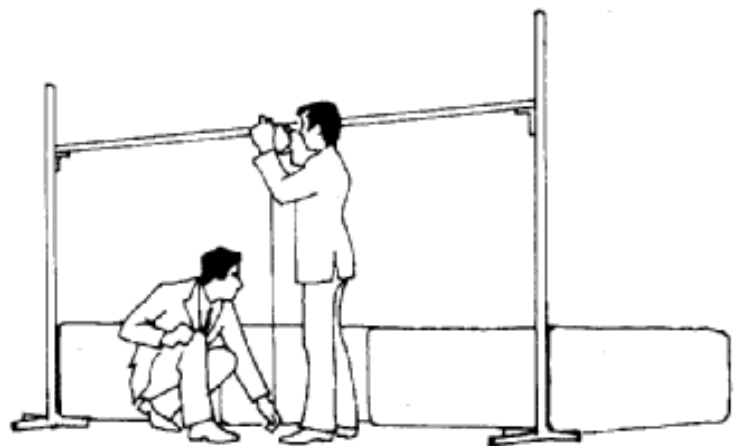
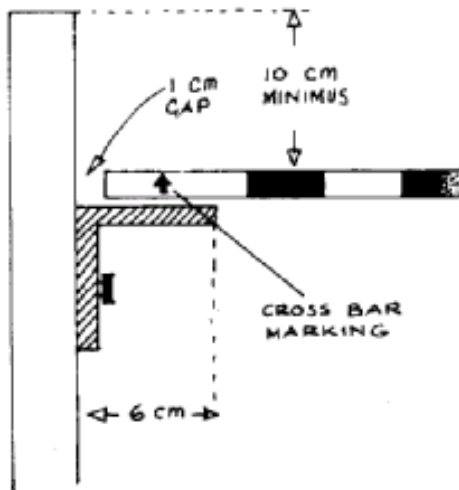

is relative to the standards depends on the type of standards being used. For many it is the back of the standard. For others it may be the centerline of the standards. Note that some vault runways are not flush with the top of the plant box so make sure to measure from the runway surface. For a record: the bar must be measured before the attempt if the bar has been disturbed since it was last measured. Remeasured following a record is no longer required. Use a steel tape for all records. Only the high school rules do not require a steel tape to be used. Starting in 2003 the ends of the cross bars in USATF and IAAF meets must be semicircular so that they can be put on only one way. Pole vault is best measured with a graduated or measured bar except at the lowest heights. Such a device can be made from a paint roller and a paint roller extender.

The height is normally measured metrically in meters and recorded to the nearest centimeter below the height measured; i.e. fractions must be ignored. If it is measured imperially as in high school event then the height is measured in feet and recorded to the nearest quarter inches below the height measured; i.e., fraction smaller than a quarter inch are ignored.



Measuring HJ Bar



Setting HJ Standards



Replacing High Jump Bar

SUMMARY OF HIGH JUMP RULES AND GUIDELINES

In the High Jump the athlete must take off from one foot. A failure to clear the bar is charged against the competitor when the bar is dislodged due to some action of the athlete or if the attempt is not made within the allotted time. Knocking the bar off the supports with any part of the body or touching the ground beyond the plane of the uprights or plane extended without clearing the bar, the attempt counts as a failure. If in attempting a jump the competitor touches the landing area with her/his foot and, in the opinion of the judge, no advantage is gained, the jump should not for that reason be considered a failure. (This is particularly true in Masters Competition.) Unless the Referee considers the take-off or landing pit has become unsuitable, the uprights or posts shall not be moved during competition. In such a case, the change shall be made only after a round has been completed if at all possible.

In summary, the rules specific to the High Jump include:

1. Normally, the standards are not moved once the competition begins, and never during the middle of a round of competition (unless they are knocked out of place).
2. The crossbar is circular with flat rectangular ends until 2003 and marked so the bottom and front sides remain constant. In 2003 the ends of the bar will be semicircular for IAAF and USATF competitions.
3. The landing pad must not extend into the plane of the crossbar. In USATF and IAAF meets it should be behind the marked foul line.
4. Shoes may not incorporate springs or have soles thicker than 13mm including ridges and heels can be no more than 19 mm.
5. A windsock should be located near the take-off area.
6. The takeoff of a legal jump is from one foot in front of the nearest edge of the uprights.
7. The starting height and all successive heights are to be determined by the Games Committee until only one jumper remains.
8. Each jumper may put up to two marks to indicate her/his approach. If the Games Committee does not supply a marker, a competitor may use adhesive tape, but not chalk or anything else that leaves indelible marks.¹
9. A failed jump attempt occurs when:
 - a) The Judge concludes that the bar fell because the jumper knocked it off, not because the wind blew it off or because the pad jarred the standard knocking the crossbar off. It is immaterial whether the jumper leaves the pad before the crossbar falls. Only in a high school meet is it a foul if the bar is knocked off as a result of the jumper leaving the pit, assuming the jumper did not hit the bar while jumping.
 - b) The jumper touches the ground or pad beyond the plane of the front edge of the crossbar, or the plane of the crossbar extended, without first clearing the bar. This plane will be marked with a 5 cm line the edge nearest the jumper being aligned with the front edge of the standards and running 3 meters beyond either standard.
 - c) If the jumper fails to jump within the allotted time (see above). Competitors are allowed a maximum of 3 attempts at each height.
10. Competitors may take all 3 attempts or pass any or all attempts.
11. A "pass" is for that height in USATF and IAAF and 3 "pass marks" should be recorded to indicate that the jumper has passed the height completely.²
12. A pass must be indicated by the competitor before she/he is called up.

SUMMARY OF POLE VAULT RULES AND GUIDELINES

Officiating the Pole Vault is conducted in a similar fashion to the High Jump. Time increments are shown in the table above. In this form of vertical jumping the competitor is aided by the use of a pole. Although the pole may be of any

¹NCAA rules do not permit any competitor's mark within 2 meters of either standard.

²The NCAA rule permits the competitor to pass on an attempt and still take 2 additional attempts at the height.

material or combination of materials and of any length or diameter, the pole's basic surface must be smooth. The pole may, however, have a binding of not more than 2 layers of adhesive tape of uniform thickness at the holding area. This tape restriction does not apply to any binding at the bottom end of the pole with protective layers of tape so long as this does not exceed 30 centimeters. In order to obtain a better grip competitors are permitted to use an adhesive substance such as resin or a similar substance on their hands or on the pole during the competition. The use of tape on the hands or fingers is not allowed except in cases where it is necessary to cover open cuts. Although gloves may not be used, forearm covers are permitted.³ The take-off box for the Pole Vault can be made of wood, metal or other suitable rigid material sunk level with the ground. The standards supporting the crossbar may be moved back up to 0.8 meters (31 inches) toward the landing area from the zero point only. Before the competition starts each vaulter should inform the official of the position he wants the standards set at during the competition. This information should be recorded on the recording sheet. If the competitor wishes to make changes during the competition, these should be made before the standards are set to his initial marks. If failing to do so, the time required to reset the standards may be subtracted from the time allotted to the athlete for that individual attempt. In all competitions the standards may not be set before the zero point which is at the top inside edge of the back of the take-off box.

In summary, the rules specific to the Pole Vault include:

1. After leaving the ground in an attempt, the competitor is not permitted to move his lower hand above the upper hand or move the upper hand higher on the pole.
2. The length of the runway is unlimited.
3. Measurements for records must be made with an acceptable steel tape or bar graduated in centimeters. All new heights shall be measured, and record heights remeasured, if the bar is displaced.
4. No marks are to be placed on the runway, but one or two markers can be placed alongside the runway.
5. A competitor may, at his discretion, commence vaulting at the starting height or any subsequent height.
6. The winning competitor is entitled to continue vaulting at the heights he determines (as long as greater than 2 cm. Increments) until he has forfeited his right to compete further by three consecutive misses.
7. Poles may not have a binding of more than 2 layers of tape at the grip end of the pole.
8. Gloves may not be worn except in a NCAA meet.
9. If the competitor clears the bar, it is not a foul if the pole passes underneath the crossbar.
10. It is not a foul if the pole breaks during an attempt. In such a case the valuter will be awarded another attempt.
11. It is not a foul if a vaulter runs outside the white lines marking the runway at any point.
12. It is considered a foul if the vaulter:
 - Knocks the crossbar off the pegs it was set on due to the actions of the competitor while vaulting.
 - Before taking off, touches with any part of his body or pole, the ground (including the landing area) beyond the vertical plane of the upper part of the stop-board of the take-off box with any part of his body or pole without first clearing the crossbar.
 - After leaving the ground places his lower hand above the upper hand or moves the upper hand higher on the pole.
 - Or any other person touches or catches the pole unless it is falling away from the crossbar or uprights. If the pole is touched and the official in charge of the event is of the opinion that the bar would have been knocked off if the intervention had not occurred, the vault shall be regarded as a failure.
 - Fails to initiate an attempt within the time allotted.
 - During the jump the vaulter deliberately steadies or replaces the bar.
 - Fails to initiate an attempt within the time allotted.
 - In high school, leaves the ground without clearing the bar.
 - In high school only, knocks the bar off while getting out of the pit.

EQUIPMENT SPECIFICATIONS:

Starting in 2003 there will be a number of equipment changes in all of the rulebooks. The peg length on the pole vault standards will be shortened to 55 mm from 75 mm for all but high school competitions so it will become necessary to check that the right pegs are being used. They remain 1/2 inch or 13 mm in diameter. Likewise the end pieces on both the pole vault and high jump bars will need to be semicircular so that the bar can only be replaced one way. All bars should be marked so that they can be replaced the same way each time. Before the bar is marked the bar should be rotated until the maximum deflection down, i.e. its most stable position. Likewise in USATF and IAAF meets, the cross bar end pieces must be semi-circular so it can only be put up one way

The specifications shown below are generally minimums for the pit pads.

³NCAA rules permit the use of gloves in the Pole Vault.

HIGH JUMP

	PIT	CROSSBAR	SHAPE
HS	4.80 X 2.40 X 0.60M	3.66 TO 4.52M	CIRCULAR, SQUARE, TRIANGULAR
NCAA	4.88 X 2.44 X 0.66M	4.00 TO 4.04 M	CIRCULAR 25 TO 30 MM
USA T&F	6.00 X 4.00 X 0.76M	3.98 TO 4.02M	CIRCULAR 29 TO 31 MM
IAAF	6.00 X 4.00 X 0.70M	3.98 TO 4.02M	CIRCULAR 29 TO 31 MM

	RUNWAY	LENGTH
HIGH SCHOOL	Semicircle	50 ft. diam.
NCAA	150 deg arc	15 to 21.3 M diam.
USA T&F		18M to unlimited
IAAF		15 TO 25 M

POLE VAULT

	PIT	CROSS BAR	SHAPE
HS	19'-8"W X 16'5" x 1FT	3.66 TO 4.52M	CIRCULAR, SQUARE, TRIANGULAR
NCAA	6M W X 5M D X 0.81M	4.48 TO 4.52M	CIRCULAR 25 TO 30 MM
USATF	6.15M X 6.00M D X 0.81M	4.48 TO 4.52M	CIRCULAR 29 TO 31 MM
IAAF	7.00M X 6.00M D X 0.80M	4.48 TO 4.52M	CIRCULAR 29 TO 31 MM

	RUNWAY LENGTH	WIDTH
HIGH SCHOOL	40.0 TO 45.0M	1.07M
NCAA	38.1M TO UNLIMITED	1.22M
USA T&F	45.0M TO UNLIMITED	1.22 TO 1.25M
IAAF	40.0M,45.0M TO UNLIMITED	1.22 TO 1.25M

Note Metal crossbars are no longer allowed in High School or USATF. End pieces for USATF and IAAF meets must be semicircular so they can be place only one way.

Pegs NCAA, USATF, IAAF 55 mm in length, HS 3 in or 76 mm
Collar for HS and NCAA where there is no pit coverage around the box.

STEP BY STEP GUIDE FOR VJ OFFICIALS ON THE DAY OF COMPETITION

This section repeats most of the information in the previous section but deals with the activities a vertical jump field official should do each time he or she is scheduled to work a competition. The difference between the various sanctioning bodies is pointed out at appropriate points.

BEFORE COMPETITION:

1. Read the applicable rules the night before the competition. Remember the words "must" and "shall" mean it is compulsory, while "should" means it is hoped the rule will be followed but it is not essential. Pay particular attention to increments for bar changes, and timing for jumps. Vertical jumps have more differences than other field events.
2. Arrive early, at least 45 minutes before the warm-up for the event is scheduled. If possible 60 minutes or more is recommended in a large meet.
3. Check in first with the Head Field Judge or Field Referee to see if there are any special rules or notes for the day, like a decision by the Games Committee to run the event using rotating flights or the amount of time an athlete can be excused. If you are the head judge, pick up the event sheet.
4. Check out the facilities:
 - a. Check the runway and pads to see if they are clean, placed correctly, dry and in good repair. Make sure pads are securely fastened together and the top pad is correctly positioned so as not to interfere with the standards or the pole. Check to make sure stands and other exposed sharp edges or metal is padded. Check the location versus zero line or foul line.
 - b. Check the runway and normal walking areas for any tripping hazards or standing water. Remove any markers left on the runway or apron from previous competitions.
 - c. Check to make sure you have needed brooms, tapes, markers, forms, pens, flags, watch, ladders, performance indicator boards, wind indicator flag and recorder stand.
 - d. Check the standards to make sure they work properly, the markings are accurate and that they are set right. Check the length of the crossbar. Check the location of the landing pit and adjust as needed. The IAAF and NCAA suggests that at least 10 cm exist between the uprights and the pad in the high jump and the same for the landing pad from the back of the pole vault box (10-15 cm). Make sure the standards and their zero indication line up with the zero indicator line, which is at the back inside edge of the pole vault box. IN USATF and IAAF competitions there must be a painted 1 cm zero indicator line which goes out to the standards for the pole vault and a 5 cm white line, probably of adhesive tape, which indicates the foul line in the high jump. See drawing below. Check the distance between the bar and the standards at the starting height and the expected winning height to make sure the standards are spaced correctly. Most standards are bent and may move in at higher heights. When layout is finalized, mark the location of the standards or the standard rails. Check the crossbar to find the side with the least sag. Mark the location of the movable end pieces indicating which side is up and which is right or left. For USATF and IAAF meets make sure they are semicircular. Mark the bottom, top or front of the crossbar so the same side will always be up. I personally like to mark the front of the high jump bar and the bottom of the pole vault bar so I can verify it is placed properly. If the end pieces easily move, remove them and put one wrap of adhesive tape on the bar and replace the end pieces. They won't turn. Find the low point of the crossbar and mark that position on both the bar and the jumping surface directly below that point on the bar using a plumb bob. The low point need not be the center of the bar. This makes it easier to make sure that the measurement is the correct one, that you measure to the same point each time and that the measurement is vertical. Make sure when the bar is level that both standards read the same. Note if you change a bar during the competition, the standards may read differently since the new bar may sag more or less. If necessary remark or reset the standards so they read correctly. Note that all bars have some sag to them. Although you would like to minimize the sag make sure that you set the bar so that it is in the most stable position, i.e. the side with the most sag is the bottom. Starting in 2003 in IAAF and USATF competitions the crossbars will have to have semicircular end pieces which will help to make sure, particularly in the pole vault, that the bar is always replaced the same way assuming you have marked it properly.
5. Erect barriers when possible to keep everyone but officiating field officials off the runway or jumping area.
6. Have athletes check in with the head event official and make sure to ask if they will need to be excused during this event to compete in another. Explain to them the rule on absence, particularly how it will be applied by you in this meet. This is an area of much misunderstanding since the rule varies from sanctioning body to sanctioning body.
7. Announce the competition order, the warm-up time and the starting height. The Games Committee should set the order. If not, it should be done by lot.
8. In a high school pole vault competition you will need to check that each competitor is jumping on a pole which is rated for his or her weight and is not using a training pole before they start warming up.

- Determine if clerks will bring out the athletes (usual in major competitions) or they will show up at the site.

LOCATION OF PLANE OF THE HIGH JUMP BAR

USATF and IAAF have defined the front edge of the vertical standard for the high jump to be the foul plane for the high jump. Thus the indicator tape for that plane starts at that line and should be marked under the bar. The line, normally of adhesive tape, will run the distance from three meters outside of the one of the standards to three meters beyond the other standard for a total of approximately 10 meters. This picture is as if you are looking down on the bar.

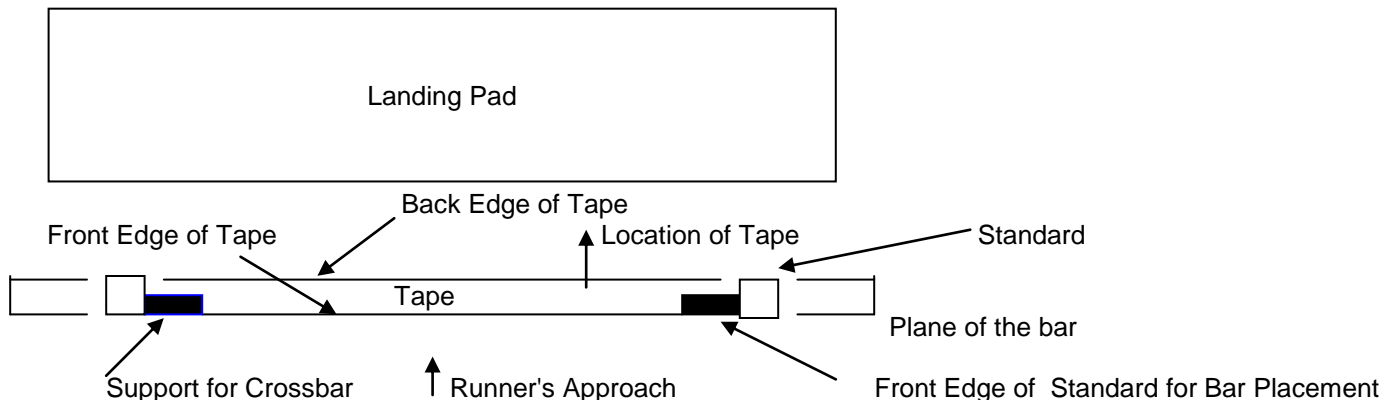

LOCATION OF THE PLANE OF THE POLE VAULT BAR

The plane begins at the top inside edge of the back of the pole vault box. All measurement for the pit and the standards should be referenced to this line. The drawing is as you are looking down on the layout from above. The zero point is where the front edge of the bar is; i.e., the edge closest to the jumper.

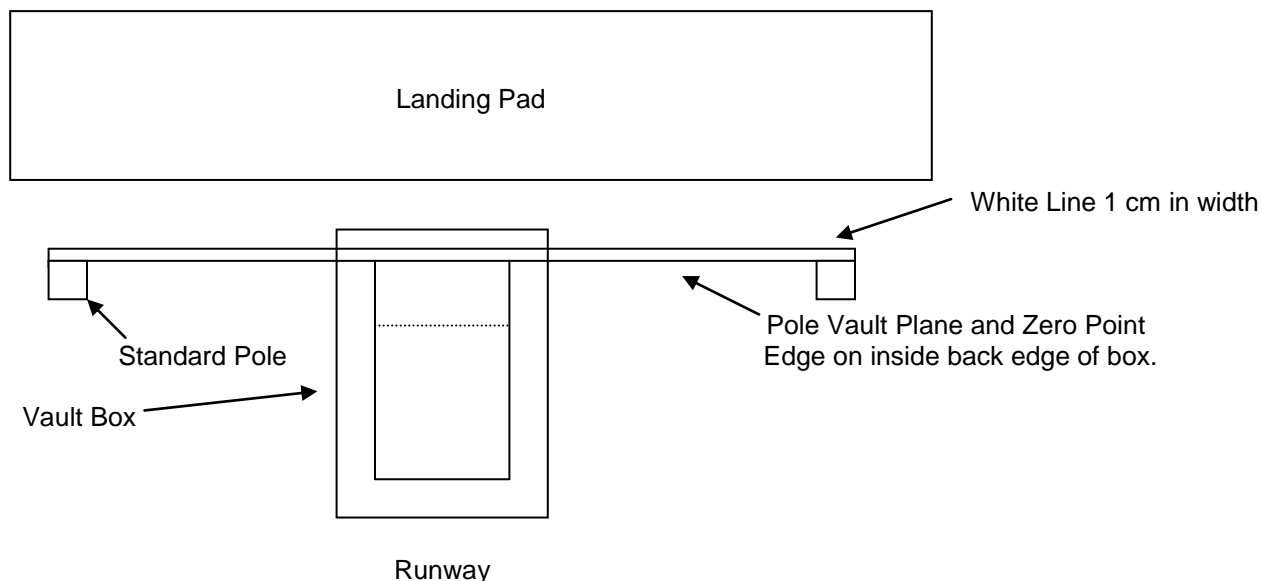

WARM-UP TIME:

- Only warm-up with officials in place.
- Warm-up should be long enough for athletes to get their marks and steps plus at least two and preferably three or four jumps. Since generally athletes are only good for 10 or so competitive jumps, many more warm-ups deters from their performance. The NCAA (6.4.1) says there will be a maximum of 15 minutes warm-up before each flight. In reality this is rarely followed and 30 to 45 minutes for vertical jumps is more the norm. No other rulebook gives any guidance on warm-up other than being consistent.
- At the beginning of the warm-up period let the athletes know how many jumps or how long the runway will be open for warm-ups.
- Always close the warm-up period off with about 2-3 minutes to go, so there is adequate time for instructions and introductions if required. Always give adequate warning of how much warm-up time remains. Having an official get in the warm-up line is the best way to terminate the warm-up period. This lets everyone know when the period is over and eliminates anyone from trying to sneak in one extra attempt. If you're using a time period this

should be done at a time when the length of the line would finish at the allotted time. Assume about 1 minute per jump if the bar has to be put up.

5. Assign someone to catch the pole and the location of the last step for both the high jump and the pole vault. Be consistent and do it for all the athletes. Do not allow the practice of tapping, i.e. assisting the competitor at takeoff. It is now a disqualification offense for the NCAA.
6. At the end of the warm-up period check the height of the bar and be sure it is level. (In a championship meet you will usually have two crossbars. Keep the best crossbar for the competition and use the other one during warm-ups. Remember to put up the competition crossbar at the end of the warm-up period.)
7. Sweep runway especially at the jump off point.
8. In the high jump check the runways for number and ownership of marks. In USATF, NCAA and IAAF a high jumper can have two marks. The NCAA also requires that they cannot be closer than two meters from a standard. The high school rules leave it up to the Games Committee. Remove all extra marks before the start of the competition. It helps if you make sure the area is clean of old marks before warm-ups begin.
9. Make sure the sideline areas and area behind field event are clear of unauthorized people when the competition begins.
10. If the jumper is not entering at the initial height then the NCAA, high school, USATF Youth and Masters Rules all allow additional warm-up time at a height change without the bar in place after a certain time period or number of passed heights. For the NCAA, a jumper gets warm-up time using the runway and the pit without the crossbar after an hour of not jumping. The time is 90 seconds for high jump and two minutes for pole vault. In the Masters, Youth and High School a warm-up jump without the crossbar is allowed after three passed heights. Such earned jumps must be taken as earned and cannot be accumulated. In high school the competitor must enter the competition at that height after taking the warm-up jump.
11. In the NCAA once the competition has begun, it shall be a foul or a missed attempt if a competitor uses the runway or takeoff area for practice purposes.
12. While the head of the event goes over instructions following warm-ups have an official:
 - a. set and measure the bar at the starting height. Check if the bar is level either using a small level or by measuring the height at both standards.
 - b. sweep the runway or takeoff area
 - c. make sure sideline areas and the area behind pit are clear of unauthorized people.

INSTRUCTIONS:

1. Go over how the event will be conducted including the applicable rules and any recent rule changes particularly early in the season.



Pre Event Meeting for Instructions

- a. Tell them the amount of time to begin their attempt - 60 seconds for NCAA, USATF or IAAF for both vertical jumps and in high school meets 60 seconds for high jump and 90 seconds for the pole vault. Tell them if you will announce 30 second (NCAA) or 15 seconds (IAAF or USATF) remaining mark or just raise the yellow flag overhead. Tell them when their time starts and that a trial only needs to be started before the time is up; it need not be completed in the time period. In both the pole vault and high jump the time increment changes once there are three or less competitors or for consecutive jumps. When the time increment changes let the athletes know at the beginning of that round. See discussion and table under Timing.
- b. Tell them that you will indicate ___ is up, ___ is on deck, and ___ is on hold or at the ready when the pit is ready. Inform them that it is their responsibility to be ready when called. Explain if you will be using "5 Alive" in rotating flights and if so how you plan to do it and when you will change to a continuous flight. ("5 Alive" is never allowed in IAAF meets. It may be used in USATF competitions until there are 12 or fewer competitors and in NCAA competitions until there are fewer than 9 jumpers at a height. The high school rule book does not address when 5 Alive should be abandoned.)

- c. Tell them the starting height, the increments, any change in increments and whether you will be measuring in feet and inches or meters. Make sure they know where the standards can be set in the pole vault.
- d. Tell them when and how to pass. If an athlete passes after being called up the athlete will be charged with a time foul and the next athlete at least in USATF and IAAF meet has the option to wait until the passing athletes time has expired before being called up.

2. Tell them what is a foul and what is not:

It is a foul in all vertical jump competitions:

- a. Over the allotted time.
- b. Breaking the plane formed by the standards and the edge of crossbar near the take off point in the high jump and or the plane extended or the plane projected up from the pole vault box and touching the ground or landing area beyond the plane with any part of the body or with the pole without first clearing the bar.
- c. Dislodging the crossbar with pole or body.
- d. Not indicating intention to pass before being called up. Passing while on deck, on hold or before is acceptable.
- e. Use of weights or grips of any kind.
- f. Steadying the crossbar.
- g. Violating the warm-up restrictions after competition begins; i.e., use of runways, apron or pit for practice unless they have been called up or have the permission of the head judge.

Apply to both vertical jumps but to only certain types of competitions.

- h. In High School events it is a foul in both vertical jumps if a competitor stumbles into the standards and displaces the crossbar, even if the bar has been successfully cleared. This is not true in IAAF, NCAA or USATF.
- i. In the NCAA in both vertical jumps if an improperly fastened support slips when a jumper hits the crossbar without displacing it, the head judge will rule no jump and allow another trial. If the bar is displaced it will be a foul.
- j. In the NCAA, USATF or IAAF if a force other than the jumper displaces the crossbar before the jumper is over, the competitor shall be given another trial.

It is a foul in the high jump only:

- k. Not jumping from one foot.

Apply to pole vault only:

- l. In the pole vault it is a foul if after leaving the ground the vaulter moves the lower hand above the higher one or slides the upper one higher.
 - m. In High School competition it is a foul if a vaulter leaves the ground in an attempt to vault and fails to clear the bar. In NCAA, USA and IAAF competitions, it is not a foul to leave the ground if the attempt is not otherwise a foul but the time will continue to run.
 - n. It is not a foul or an attempt if during an attempt the pole breaks.
 - o. No one shall be allowed to touch the vaulting pole unless it is falling away from the crossbar or uprights. If it is touched, however, and the head of the event (USATF and Referee for IAAF) is of the opinion that, but for the intervention, the bar would have been knocked off, the vault shall be regarded as a failure. In high winds the NCAA will allow the pole to be caught if in the opinion of the head official, the pole might blow into the bar or standards even if it were properly released.
 - p. It is not a foul if the pole passes underneath the bar as long as it doesn't touch the bar.
 - q. It is a foul if in high school you use a competition pole rated for less than your weight either during warm-ups or the competition. If the pole is improperly marked or too light, you will be disqualified.
 - r. In high school events it is a foul if the athlete puts the upper hand above the top hand hold band.
 - s. Tape may not be used on fingers or hands unless to cover an open cut. Taping the wrists or use of a forearm guard is OK. Gloves may not be used in the pole vault except in a NCAA meet.
 - t. Using tapping during warm-up or competition is grounds for disqualification from the event.
3. Check the pole vault poles for two layers of uniform tape only on the portion being held. Competitors may not use each other's poles except with the consent of the owner. There are no specifications for vaulting poles.
 4. Tell them they can put talc, spray, or similar substance for a better grip on their hands and poles. But they cannot spray their shoes or the runway. In the NCAA only, they may use a glove.
 5. If numbers are required, check that they are on their uniform. Vertical jump athletes may use only one number on either the front or back.
 6. Tell them that they should not cross the runway except at the end and that once the competition has begun they cannot use the runway or pit for practice unless they are called up.

7. Confirm who has another event going on at the same time and explain what they must do when they leave. Explain what you expect and how their absence will be handled and the options they have to get their jumps in.
8. Explain the use of the red, white and yellow flags to indicate a fair or foul jump and availability of the pit and time remaining.
9. Indicate the increment that the bar will be raised for this competition, including any decreases in the size of the increment at higher heights. Also indicate increment for first place ties. This information is essential so the jumpers can determine their strategy.
10. Have the athletes remove any objects or jewelry that might cause a safety problem. In high school competitions check that athletes are not wearing jewelry except watches or religious medal taped to their chest.
11. Read the competing order. Confirm starting height/passes and the initial setting for the pole vault standards for each competitor. This information should be recorded.
12. Line up competitors for introductions if needed.
13. Starting heights should be set to allow for normal progression to records or qualifying heights.
14. Check the number of markers belonging to each athlete. Other than for high school where the Games Committee sets the number, and in Youth Meets, no athlete should have more than two markers. If they do, remove the extra ones. In the NCAA meets: Shoes may not be used as markers. Markers for the high jump must not be longer than 15 cm and cannot be within two meters of the standards.

COMPETITION:

1. Do not call up a competitor until the pit, standards and crossbar are ready for competition. Start your clock when the athlete is called up and do not stop the watch until the jump is completed or fouled. Standards may be set at different distances in different rulebooks. Where 0 is the inside edge of the back of the vaulting box.

Rulebook/Division	Standard Limits
IAAF	0 cm to +80 cm
USATF Open & Masters	0 cm to +80 cm
USATF Youth	+40 cm to +80 cm
NCAA	+45 cm to +80 cm
High School	+40 cm to +80 cm



Setting the PV Standards



Setting & Measuring the Measuring Bar



Replacing the PV Bar

2. Watch the plane of the standards to make sure it is not broken by the athlete by touching the pit or the ground beyond the plane with any part of the body or the pole without first clearing the bar. In Master's competition an athlete may touch the landing surface before clearing the bar, but may not use the pit to any advantage.
3. Watch that the high jumper takes off from one foot.
4. Watch the vaulter to see if he leaves the ground without clearing the bar, since that is a foul in High School.
5. The pole vault pole cannot be caught unless it is falling away from the bar or standards. This is generally only important when the crossbar is lower than the height of the pole (i.e. in Women's, Combined, Youth and Masters' events). On windy days it is important to determine if the pole is pushed back by the vaulter with sufficient force so that on a calm day the pole would fall back away from the bar. My guideline here is did it become perpendicular before it started to move toward the bar. If it did then normally it would have fallen away. If it isn't pushed back hard enough then it must not be caught and you must let it hit the bar to see if it will displace it. If it does it is a foul; if it doesn't then it is a fair jump. Make sure an experienced official is assigned to that duty.
6. Let the crossbar settle down if it is hit by the competitor before calling the jump fair. When satisfied that the bar will stay in place, indicate with a white flag a fair jump, steady the crossbar and call the next jumper. If a failure, raise the red flag. If it is clear that the bar has been displaced by a force not associated with the competitor (e.g. a gust of wind, someone else hitting the standard) then a) if such a displacement occurs after the competitor has cleared the

bar without touching it, the jump should be considered successful and b) if such displacement occurs under any other circumstances a new attempt will be awarded.

7. Make sure that the jumper does not steady the crossbar.
8. If the bar comes down replace it. Set the pole vault standards at the recorded mark for the next jumper and call the next jumper. If the jumper wants to change the mark then he must inform the proper official before the standards are set or it should be done after he is called up and his time is started.
9. If not otherwise fouled, a jumper may go back and retry his jump. If this happens, the time will not be reset unless the head event official decides that due to special circumstances it should be.
10. The recorder can be where needed depending on what other jobs he or she has and should record each jump on the event sheet as follows:

	Cleared	Failed	Passed
ALL	O	X	-

11. If a competitor passes a trial in an USA Track & Field or an IAAF meet, the athlete forfeits his or her right to jump again at that height. In NCAA and High School you pass only one trial at a time unless the jumper indicates otherwise. Remember in high school, USATF Youth and Masters and NCAA, a jumper may get a run through with the bar down when:
HIGH SCHOOL: If athlete passes three consecutive heights and is entering the competition at this height.
COLLEGE: If an athlete has not taken an attempt in over an hour with the permission of the event official without entering. Ninety seconds is allowed for the high jump and 120 seconds for the pole vault.
USATF Youth and Masters: If an athlete passes three consecutive heights, the run through must be taken as earned without entering.
12. A tardy contestant cannot enter a vertical jump competition unless checked in and excused to go to another event in a high school or NCAA competition. Alternatively an entered and declared athlete shall start at the height at the time of his arrival unless he has missed, and is therefore considered to have passed his first turn at that height. In that case he can start at the next height.
13. When all have made the height, move the bar up and check the level and height. The increment for the raise should never increase, although it may be decreased. Read those jumping at the next height to make sure they know the order and who is competing at this height.
14. Jumpers are eliminated when they have three consecutive failures no matter the heights.
15. In the vertical jumps measurements, even for records, are made only before the jump. Only when the standards move up or down do you need to measure the height. At a record height you should remeasure the bar each time the bar is hit or displaced. All records but high school records must use a steel tape or a scientific device.
16. Continue on until all athletes have made or missed three times at a height. Then raise the bar.
17. Announce the order for all athletes jumping at the new height. Confirm who is passing. When at the start of a height there are three or fewer jumpers, announce the increased time for trials.
18. Once a competitor has won, the athlete has the right to continue jumping until eliminated at a height the athlete chooses. The smallest increment is 2 centimeters in the high jump and 5 cm in the pole vault. Announce the time allowed for each trial.

RECORDING:

The job of clerking and recording the results of a vertical jump competition can be very challenging. It is important that the recorder understand the tie breaking rules and the passing rules for the competition. Because of all the passing involved it becomes difficult at times to know who is in the competition at a given height, particularly if you are using rotating flights. I have found one way is to use a highlighter. When a competitor has qualified to jump at the next height



Recorder



Pole Vault Officials at Bar



Pole Vault Officials at Pit



PV Officials and Standards Board

I highlight their marks one round at a time as they qualify for the next round. That way all of the highlighted athletes are still in the competition. Those passing also are highlighted at the start of the round when they confirm they are passing

the height. Thus you only look at highlighted rows for calling up people. Anyone that is out of the competition has a line drawn through subsequent heights and is not highlighted. Passing athletes are highlighted but they have P for their performance. Thus everyone still in the competition in any round is highlighted. When you are doing 4 or 5 alive use your finger as a stop point or put a rubber band on your clipboard at that position.

MEASURING:

1. Crossbar heights normally should be recorded in meters to the nearest shorter centimeter. If it is measured in feet and inches then to the nearest shorter 1/4 inch.
2. Normally a steel tape should be used and measured from the low point of the upper surface of the crossbar to a point directly below the point on a perpendicular line. Remember this is not necessarily at the mid point of the bar, although it often is. Make sure you measure perpendicularly from the lowest point of the upper surface of the bar to the runway. Remember your geometry, the shortest distance between two points is a straight line and in the vertical direction it is a line perpendicular to the base.
3. I recommend that two officials read the tape when possible.
4. The bar should be checked at least initially and then every few heights, if not every height increase. Periodically the bar should be checked to make sure it remains level.
5. Make sure the measurement agrees with the height recorded on the sheet. It is useful to show both the metric and the imperial equivalent at the top of each column.
6. If the height will be a record then you will need the measurement confirmed by three certified officials under the general supervision of the field referee. In all competitions for a record the bar height must be measured with a steel tape before a jump. High school rules do not require a steel tape but its use is a good practice.

THREE OR FEWER JUMPERS REMAINING IN COMPETITION:

In all cases and in some combined events, when there are three or fewer jumpers remaining in the competition, the time for jumps changes (see the earlier table). The increment the bar moves up will remain the same or become less as specified by the Games Committee. Only when an athlete has won the competition (except a combined event) may he or she set the bar. Note if there are two remaining the increment is that set by the Games Committee or you as the head official before the beginning of the event. It is ok to have a large increment at lower heights and then a smaller increment at higher heights. However the minimum increment is 2 cm in the high jump and 5 cm in the pole vault for USATF until only the winner remains unless it is to go to the record height. When you only have three jumpers remaining, assuming all have had at least one fair jump, you can start to score the event. You now know how many jumpers will get places. Start at the bottom and work up. Check the jumpers who went out at the lowest height. Apply the tie breaking rules as necessary and assign them their places. Continue to work up until you get to the highest height(s) that the three remaining jumpers have cleared. Until they go out you can't finalize the result for that round.

AFTER THE COMPETITION:

1. When you are down to two jumpers do the scoring and checks to make sure you know whether you will be in a jump-off situation. In the event of a tie, the procedure for breaking the tie is a) lowest number of attempts at the tying height, b) lowest number of total misses up to the last height cleared. Passes don't count for anything. If there is still a tie for first place then the tying competitors will get an additional jump at the lowest height attempted by any of the tying competitors above the tying height. Each athlete must jump or be eliminated from the jump off. There is a single attempt at each height. If the tie is not for first place after applying a) and b) then the tie is not broken. There is more on scoring and ties in the section TIES /PLACES. When the event is over, get the other officials check the result and sign the sheet.
2. Announce the results to the competitors and then give the results to the runner, head field judge or the announcer.
3. Close up the venue so no one will use it without supervision until after the meet. This can be done by putting a cone on the runway, taking the bar down and preferably putting it away and putting on the pad cover.
4. Check in with the head field judge to see if you or part of your crew is needed to officiate at another event.

APPLICABLE MAJOR RULE REFERENCES:

This is a list of the major rules but there are other sections that you will need to be familiar with to officiate the vertical jumps. You should be familiar with each of the rulebooks that apply to the level of officiating you do.

	HIGH JUMP	POLE VAULT
HIGH SCHOOL	2.2, 7.1-3	2.2, 7.1, 7.2, 7.4
NCAA	1.4, 2.5, 6.1-4, 7.1.5	1.5, 2.6, 2.7, 6.1-3, 6.5, 7.1.5
USATF	90, 93.1-11, 215, 217	90, 93.1-7, 93.12-19, 204, 215, 217
IAAF	180, 181, 182	180,181,183

SUGGESTED PERSONAL EQUIPMENT LIST FOR VERTICAL JUMP OFFICIALS

Minimum Required

Pens or Pencils
Chalk
Watch
Flags (Red, White & Yellow)
Rule Book
5 or 10 Meter Steel Tape

Optional

Clip Board
Highlighter
Field Event Forms
Record Forms
Level (High Jump)
Measuring Pole (HJ & PV)
Adhesive or Masking Tape
Towel
Plumb Bob (HJ)
Cone for Runway
Wind Sock
Chalk for Athletes

High Jump

(Second Pit is Mirror Image)

Grass Field

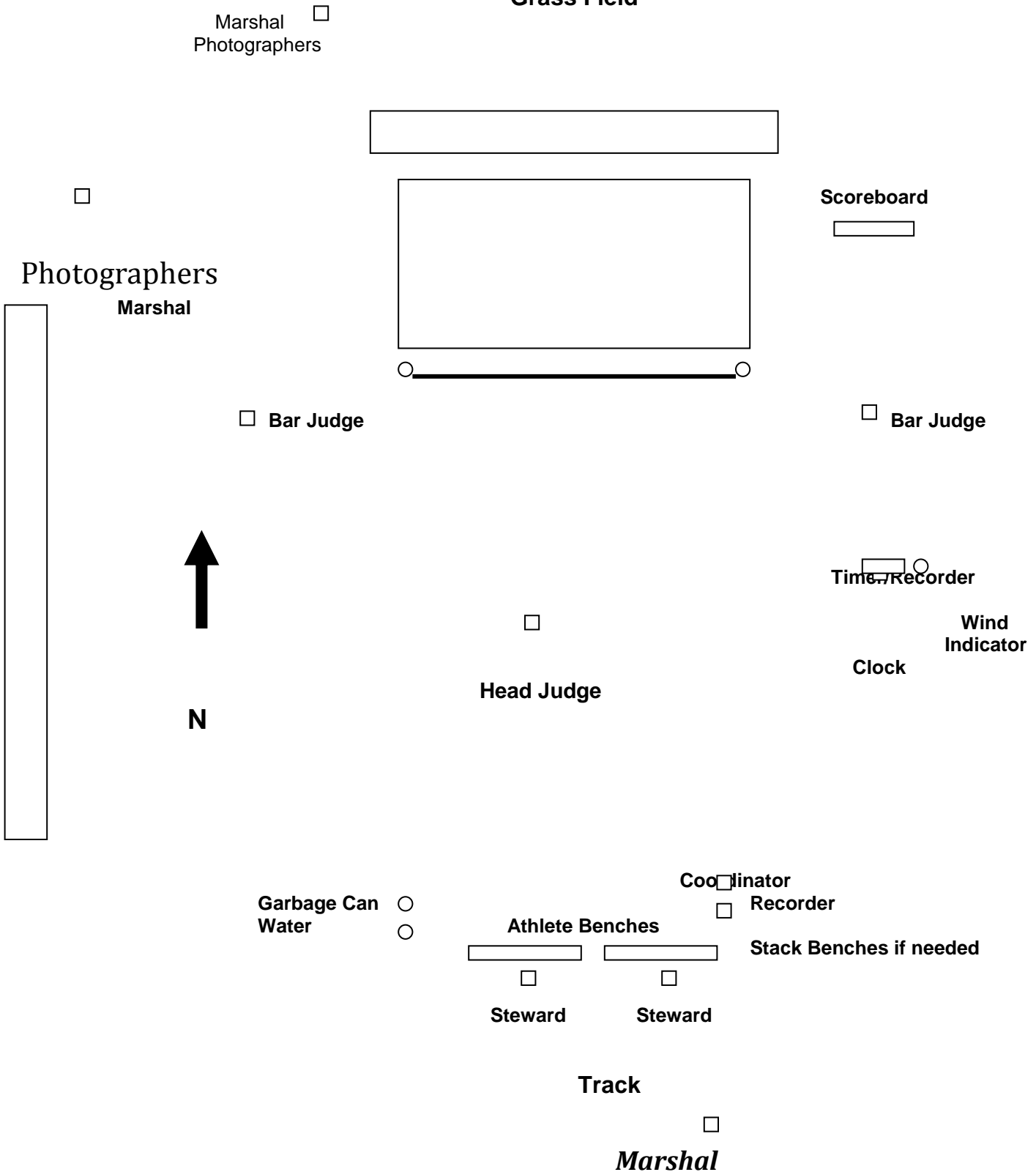

6 Vertical Jump Officials

2 Marshals
2 Stewards

High Jump Venue: There will be two high jump pits located on the south D ring. These should be set to give equal room for both. On Day 1 they will be set up and ready to go. The east pit will be moved over after competition to make room for the hammer set up. On Day 5 after the hammer the east pit may have to be adjusted. The hammer should be the only interference except near the end when track events may start. Thus all equipment must be kept on D area.

- All tape or markings from previous events should be removed.
- Set up the pits so that the back of them is just on the grass.
- Set up the standards so they are a few inches in front of the pads. Check to make sure the standards are vertical and the bases level. Validate that the height read on the standards corresponds to the actual height. Block the standards so this is the case. Run the standards up and down from 1.5 meters to 2.5 meters to make sure the bar fits properly at all heights. Mark the location of the standards with tape on all four sides. Make sure there is no more than 2 cm on either end on the average.
- Remove the curbing from the track in the area where the athletes will be jumping. Most of the time there will not be a track event but toward the end they may be starting so curbing may have to be put in and removed or cones placed for longer races. A member of the field crew should do this. Note the outer edge of the cones should be on the edge of the line, which defines lane 1's inner boundary.

High Jump Equipment Check List (each venue)

	By Technical Group	By Miller Athlete Staff	By Officials
Pad		Put Out	
2 standards	Locate	Put Out	
2 bars		Put Out	
1 Electronic Scoreboard		Put Out	
1 Countdown Clock		Put Out	
1 Wind Indicator			
1 ladder (men only)		Put Out	
1 5 M steel tape			
1 30 M tape			
10 Chairs		Put Out	
1 Performance Board for Height		Put Out	
2 Drink Containers (Water + Electrolyte)			
1 Garbage Can			
2 Athlete benches (seat 8)		Put Out	
1 Tent (if after 11a.m. & before 6 p.m.)		Put Out	
1 Yellow Flag			
1 Red Flag			
1 White Flag			

Pole Vault

Note: Mirror image if using east pits. Will use longer runway on south side for finals.

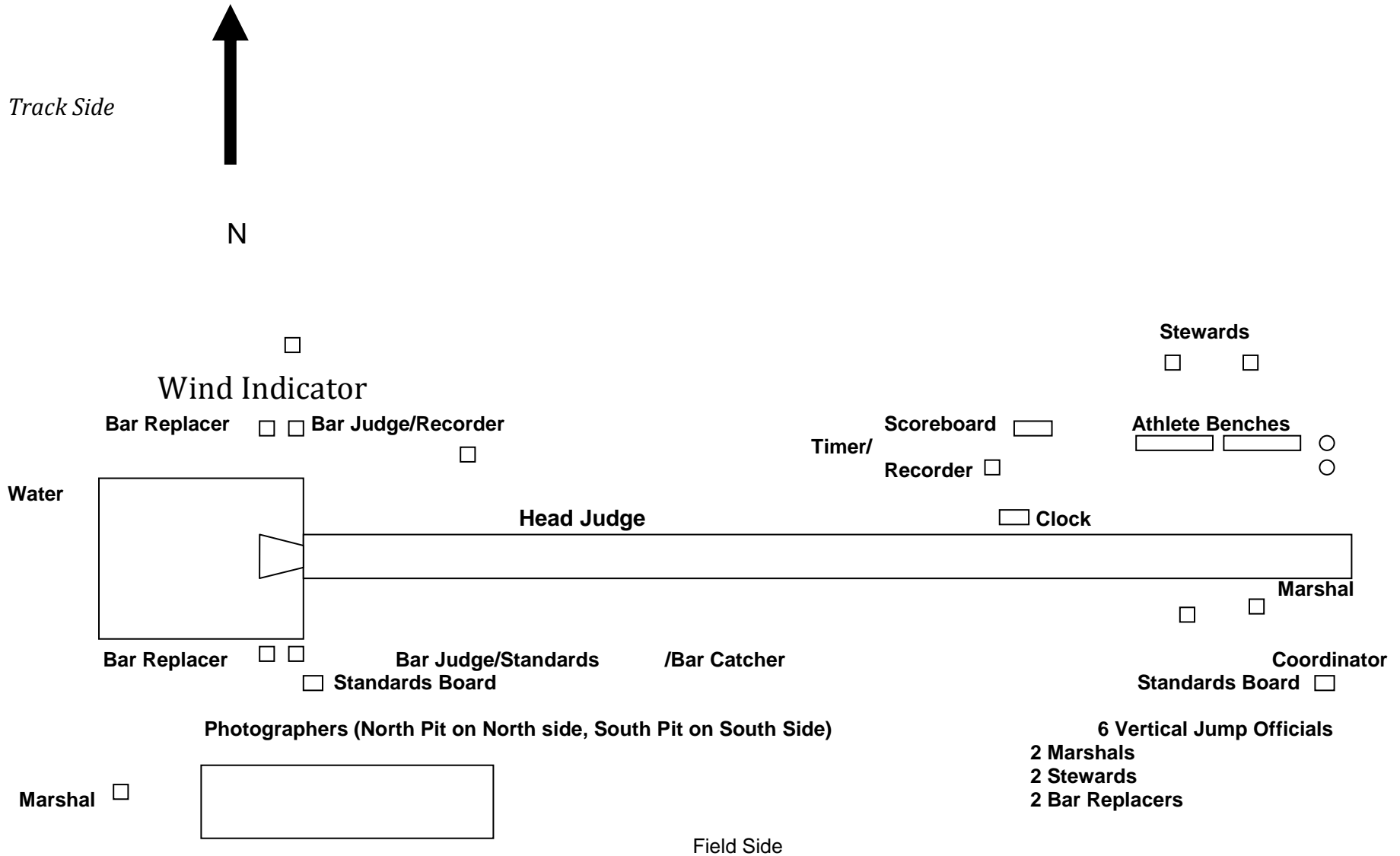

Pole Vault Venue: There are two runways running east and west on the north D ring. They have vaulting boxes at both ends. We expect the prevailing wind will be such that we will use the boxes at the East End during the meet. The main interference will come from the shot rings, which are very close to the south runway. There is some overlap of the heptathlon shot on Day 1 during warm-ups. There will be limited time between the end of Decathlon Pole Vault and warm ups for the Women's shot put. But it shouldn't pose a problem.

- All tape or markings from previous events should be removed.
- Set up the pits so that the distance from the box to the pit is approximately 10 to 15 cm on all sides.
- Set up the pole vault standards and zero the tapes on the pole vault pads. CSUS has marked each Pole Vault runway with the zero point for the standards. Please make sure the back of the standards is at the front of the line indicating the zero point when you set up the pits. Check to make sure the standards are vertical and the bases level. Validate that the height read on the standards corresponds to the actual height. Block the standards so this is the case. Run the standards up and down from 3.5 meters to 5 meters to make sure the bar fits properly at all heights.
- Place an "A" frame and a Christmas tree for poles at each runway, which will be in use.
- Place a performance board for indicating standards settings at the pit as indicated on the diagram and at the end of the runway where the flight coordinator will be located.
- Make sure to bring out two bar raisers and one measuring bar per runway.
- Make sure to have two pole vault bars for each pit. Each bar should be tested and marked to indicate the bottom of the bar. The top of the bar should be chosen by checking the deflection of the bar. The top is that side which has the least deflection. Adjust the end pieces accordingly and then mark the bar and end pieces to make sure that it is replaced the same way each time.
- Place the countdown clock and scoreboard about half way down the runway.

Pole Vault Equipment Check List (each Venue)

	By Technical Group	By Miller Athlete Staff	By Officials
Pad	Adjust	Put Out	
2 standards	Adjust	Put Out	
2 Bars	Mark	Put Out	
2 Bar Raisers		Put Out	
1 Electronic Scoreboard		Put Out	
1 Countdown Clock		Put Out	
2 A Frames for Pole Bags		Put Out	
1 Christmas Tree for Poles		Put Out	
1 Wind Indicator	Put Out		
1 7.5 M steel tape			
1 50 M tape			
12 Chairs		Put Out	
1 Performance Board for Height		Put Out	
2 Performance Boards for Standards		Put Out	
2 Drink Containers (Water + Electrolyte)			
1 Garbage Can			
2 Athlete benches (seat 8)		Put Out	
1 Tent (if after 11am & before 6 p.m.)		Put Out	
1 Yellow Flag			
1 Red Flag			
1 White Flag			
1 Chalk Holder		Put Out	

High Jump Officiating Positions

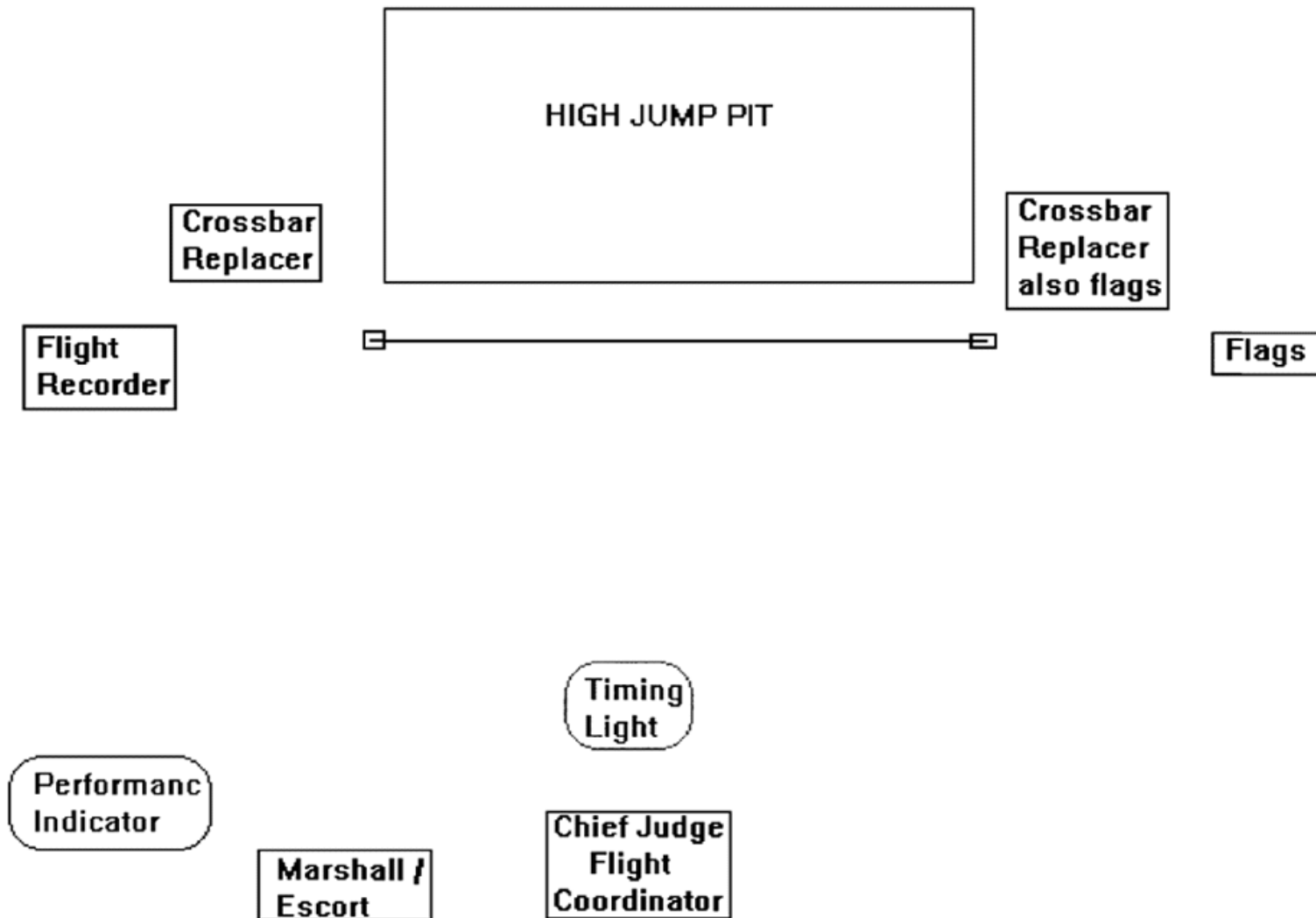

USATF OFFICIALS VERTICAL JUMP POSITIONS AND ASSIGNMENTS

Meet: _____

Date: _____



POLE VAULT

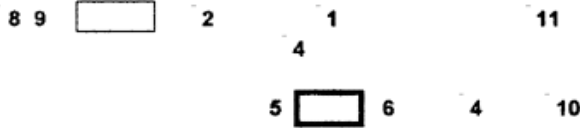
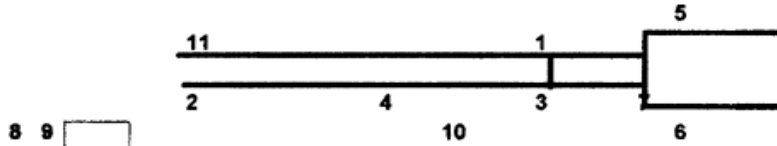

HIGH JUMP

Official's Assignment	Time _____ High Jump M	W	Time _____ Pole Vault M	W	Time _____ High Jump M	W	Time _____ Pole Vault M	W
--------------------------	------------------------------	---	-------------------------------	---	------------------------------	---	-------------------------------	---

1. Event Head/Flags
2. Flight Coordinator/
Clock Operator
3. First Recorder/Judge
4. Second Recorder/
Runway Official
5. Bar Raiser/
Standard Setter
6. Bar Raiser/
Standard Setter
7. Pole Catcher
8. Escort
9. Escort
10. English/Metric Board
11. Marshall

Pole Vault Officiating Positions

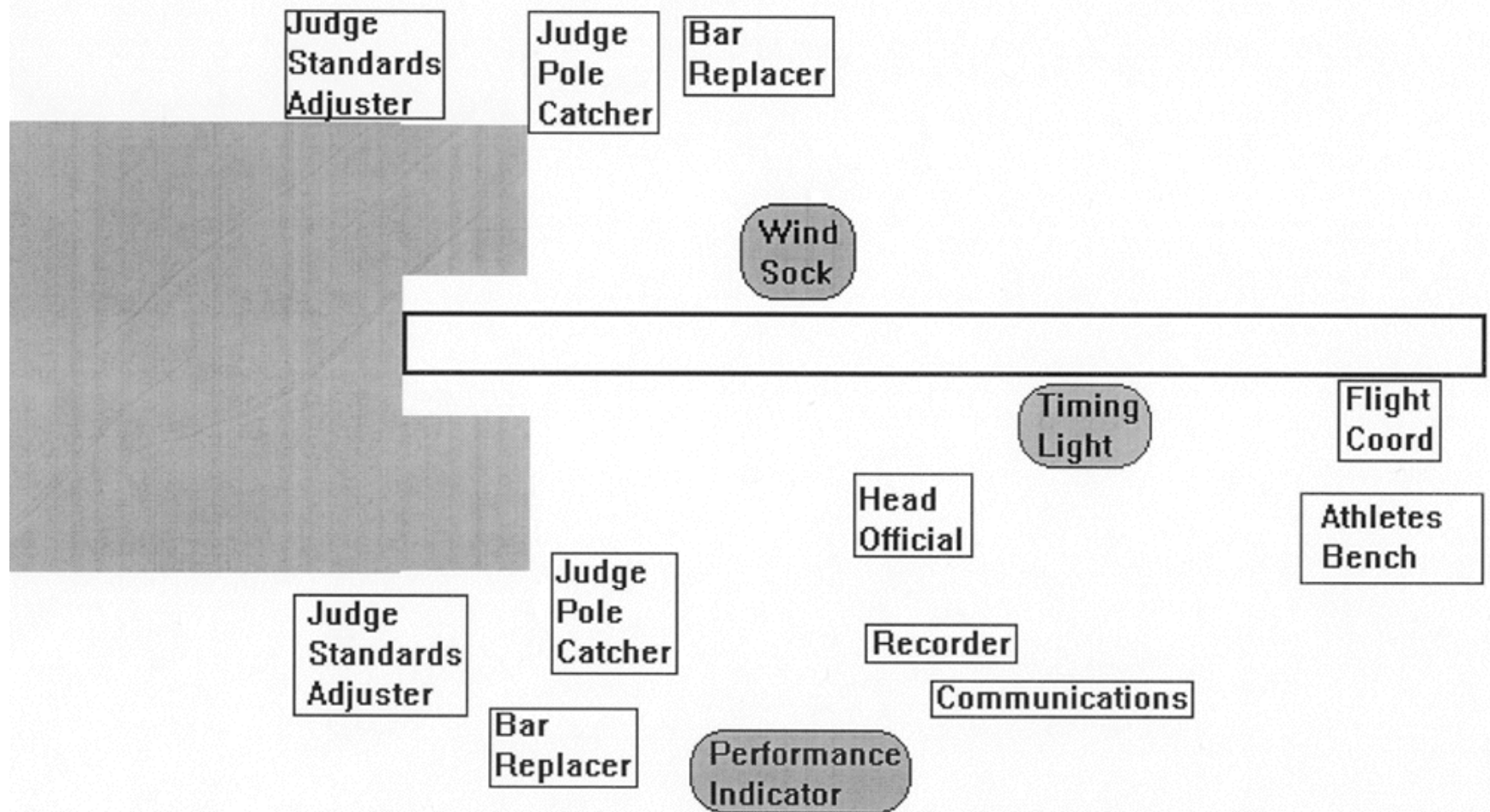



Guidelines for Vertical Jump Pre Competition Activities

Pre Meet Meeting Questions

1. Under which rules will the meet be conducted?
2. How many officials are assigned?
3. Where is the Clerk?
4. How much warm-up time is to be given?
5. How many athletes go to the finals if a qualifying competition?
6. Are there any special rules or instructions?
7. Who is the field referee?
8. Are there qualifying heights?
9. Who gets results and where do they go?
10. Who will bring in the athletes?
11. Is there a time clock?
12. Are there performance indicator boards? Who to operate?
13. Will there be athlete introductions?
14. Will there be a communicator?
15. Who is the oversight committee representative? (National Meets)
16. How will drug testing be done?
17. Will there be marshals?

Meet Day Questions

1. What are the qualifying heights, if any?
2. What is the meet record?

Items for Field Officials Meeting

1. Go over flag coordination.
2. Assignments for the day (rotate if possible)
3. March out and back or not

Activities before Warm-ups

1. Check Site for markings, safety
2. Check in Athletes (get their starting height estimate, their vault standards setting, and see if they will need to be excused)
3. Give pre warm-up instructions
 - a. How much warm up time
 - b. Procedures for warm-ups
 - c. Sitting on bench if available
 - d. Qualifying height, if any

- e. Check for taping, gloves and shoes
- f. If numbers, location- front or back or both
- g. Warn about use of too light poles
- h. Need of escort if you leave the competition area
- i. What you need to do to see your coach
- j. Use of chalk/spray on hand not on implement except in NCAA
- k. Warm up on runway only
- l. Use clock if available for warm-up period
- m. Starting height in vertical jumps and increment

Instructions before Competition

1. Flag indicating fair or foul will be raised after you leave the pit
2. The clock is your responsibility, if none then call at 15 sec (USATF/IAAF) or 30 NCAA.
3. Time for fair attempt, 1 min. Unless the HS then 1 1/2 min for Pole Vault.
4. How will call athletes up
5. How many to qualify
6. Warn that there is no warm-up in the competition area, and no use of poles period.
7. Where to go after event and comments on dope control, if any
8. Competition order
9. Check gloves and hands for taping
10. If you want to protest a call, do so immediately; measure but the head official keeps it and does not announce.
11. Go out along line for introductions, line up in competition order
12. Passing before called up, Pass jump/ height (IAAF/USATF)
13. Use of 5 alive or not and when end
14. When get run throughs
15. When time starts
16. Breaking the plane
17. Use of runway only when you are up
18. If high school tie breaking procedure and pole weight
19. If windy, bar movement
20. Starting height, increment (usually 5 cm HJ and 15 cm PV) and passes
21. Check marks, usually 2
22. If athlete leaves the competition area, procedure

Competition Period

1. After each round verify marks.
2. If record, measure with steel tape before each attempt.
3. Jump off

HJ	HS (1"), NCAA/USATF/IAAF (2 cm)
PV	HS (3"), NCAA/USATF/IAAF (5 cm)